



# George



**Owners Handbook**  
For the George Locomotive

# Operating Instructions

**IMPORTANT:** Read these instructions carefully before operating the locomotive.

The following items are required for running this engine and are not included with the model.

**Fuel** Butane gas. See 'Filling the gas tank'

**Water** See 'Filling the boiler'

**Lubricating oil** See 'Lubrication'

## SAFETY PRECAUTIONS

This is a working model locomotive using steam under pressure and highly flammable fuel. Provided it is operated with reasonable care and attention, no problems should arise.

It is intended for use out of doors and must only be operated in a well-ventilated area.

Whilst the locomotive is in use, hot gasses are exhausted up the chimney and excess steam frequently blows off through the safety valve even when stationary, so operator and spectators should not bend over the model.

As you will appreciate, this is not a toy and is therefore unsuitable for young unsupervised children.

Follow manufacturers recommendations regarding the safe storage of Butane gas canisters.

Some areas of the model will get quite hot whilst it is operating, so a pair of gloves are provided in the tool kit for your protection.

Always have to hand either a fire extinguisher or wet cloth when operating the model.

# George Instruction Booklet



## CONTENTS

Tool kit.	Page 4
Running in.	Page 4
Access to controls.	Page 4
Coupling Engine and Tender.	Page 4
Identification of parts of the locomotive.	Page 5
Preparations for operation.	
1. Filling the Gas Tank.	Page 6
2. Filling the Boiler.	Page 6
3. Lubrication.	Page 7
4. Lighting the Burner.	Page 8
Running the locomotive.	Page 9
Driving manually.	Page 10
Driving by radio control.	Page 11
Storage between operating sessions.	Page 12
Altering wheel gauge.	Page 13
Trouble shooting & maintenance.	
Steam Leaks.	Page 13
Regulator.	Page 14
Radio Control.	Page 15
Gas System.	Page 15
Boiler and Gas Tank Certificate, ( <i>EC Declaration Of Conformity</i> ).	Pages 17 & 18
Service and Parts.	Page 20

## **TOOL KIT**

The following items are included with your locomotive.

One 60ml bottle of special steam oil for use in the cylinder lubricator.

One 60ml syringe with plastic tube for filling the boiler with water.

One set of spare washers and 'O' rings.

One spare gas jet.

One Allen key for cylinder socket cap screws.

One pair of protective gloves.

One cleaning duster.

One wheel setting (back to back) gauge and key.

## **RUNNING IN**

All locomotives are extensively test run before leaving the factory, but they will still require a certain amount of running in when new, to overcome initial tightness and allow valves etc. to 'bed in'.

## **ACCESS TO THE CONTROLS**

For normal operation, all controls are accessible without the need to remove any part of the locomotive. For access to the gas tank when filling, the cab roof hinges up from the side. Care should be taken when opening the cab roof. Gently grasp either side of the roof hinge and firstly lift the hinge vertically upwards. This will lift the hinge clear of the cab, and allow the roof to then tilt to the side. The gas regulator is accessible through the rear of the cab, and on manual control engines, the steam regulator is accessible through the right hand cab doorway and reversing lever through the left hand cab doorway. The radio control receiver, batteries and switch are housed in the tender. Batteries are not included.

## **COUPLING ENGINE AND TENDER**

The tender has a steel pin under the front which should be fitted into one of the two holes in the draw bar from the engine. Use the first hole for close coupling if running on large radius curves, or the second hole if the curves are tight.

On radio controlled versions, the servo leads pass through the rear buffer beam and should be coupled to the leads underneath.

## IDENTIFICATION OF PARTS OF THE LOCOMOTIVE

Radio controlled version illustrated

- 1 ) Lubricator drain screw.
- 2 ) Lubricator filler cap.
- 3 ) Reversing servo (this is replaced by a reversing lever on manual models).
- 4 ) Pressure gauge.
- 5 ) Safety valve.
- 6 ) Gas regulator.
- 7 ) Gas filler valve.
- 8 ) Steam regulator.
- 9 ) Steam regulator servo and linkage (not fitted on manual control engines).
- 10 ) Gas burner.

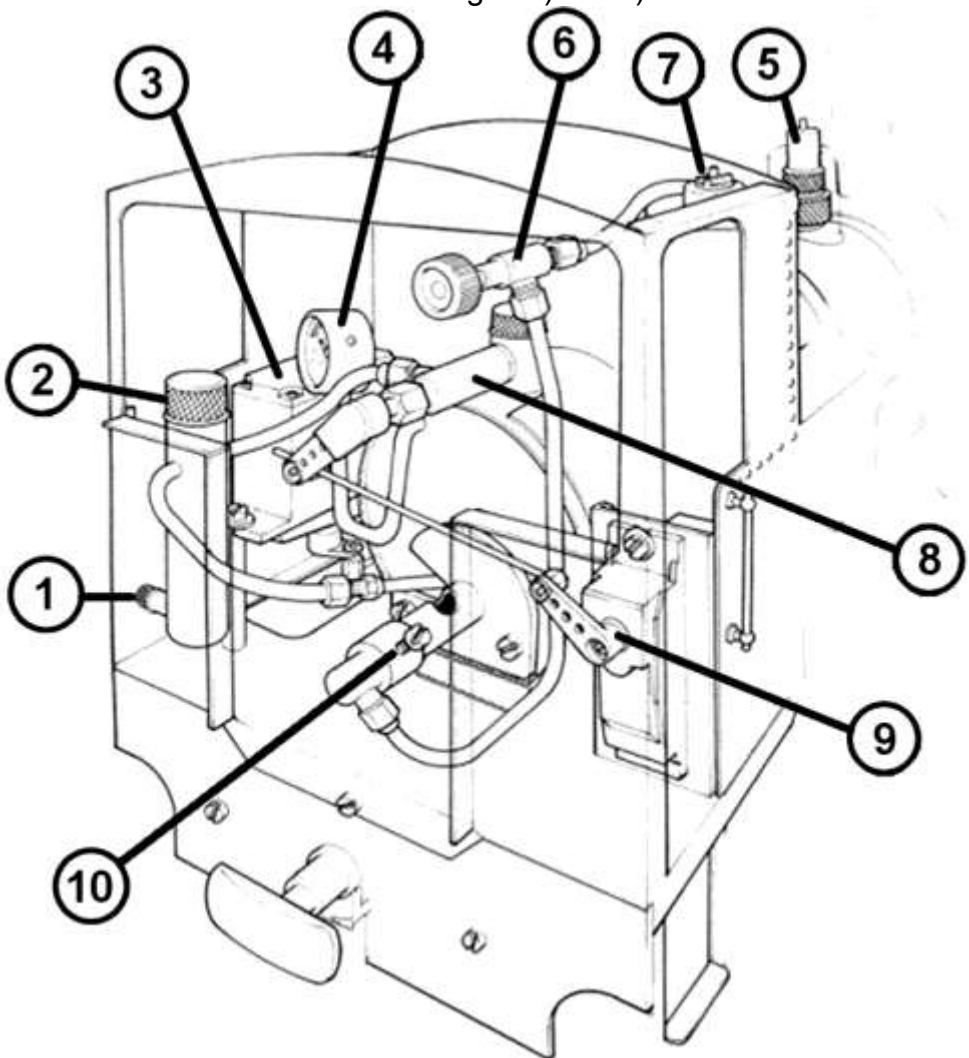

## **PREPARING FOR OPERATION**

The locomotive must be serviced before being operated. It is important to perform all the following operations.

### **1) FILLING THE GAS TANK**

The filling of the gas tank should only be carried out in a well-ventilated area, where there are no naked lights or other lighted locomotives close by. Ordinary Butane or Iso-butane gas (as used in gas cigarette lighters) is the preferred fuel, though for economy, the larger canisters as used for blowlamps or camping stoves etc. are better. The larger canisters have an EN417 threaded self sealing valve on top and require a special adapter to couple up to the filler valve on the locomotive. A special brass gas filler adapter is obtainable from your local garden railway supplier or direct from **ROUNDHOUSE**.

Mixed gasses are also available and may be used if ordinary butane or iso-butane are not available, but see 'Gas System' section for more information on this subject. Before attempting to fill the gas tank, make sure that the gas control valve is closed by turning it clockwise.

The gas tank filler valve is on top of the tank under the cab roof. Invert the gas canister and place its nozzle over the gas filler valve. Support the tank from underneath and press the canister down.

The gas will be heard hissing as it enters the tank and a small amount will escape around the valve. This is quite normal and is the tank venting as the liquid enters.

After about 20 to 30 seconds, liquid gas will emerge from the valve showing that the tank is full. Remove the canister immediately.

### **2) FILLING THE BOILER**

A syringe and plastic pipe are supplied for filling of the boiler.

The boiler is filled with water through the safety valve bush, housed inside the brass dome on top of the boiler. The brass dome is a substantial and heavy item, being turned from solid brass. Care is needed when removing the dome, especially when the engine is hot, as the dome itself will be hot. Take care not to drop the dome onto the locomotive, as the weight of it may damage the model. Lift off the brass dome then remove the safety valve by unscrewing the large knurled plug into which it is fitted.

Using the 60ml syringe and plastic tube supplied, fill the boiler fully to the top with clean water. Distilled water is recommended if available. As an alternative in soft water areas, clean tap water can be used. Also, rain water or water from a dehumidifier may be used provided that it is adequately filtered. Many people use rain water passed through a wine or coffee filter to remove any particles or debris. Do not use deionised water as this type of water in the long term, may cause damage to the boiler and fittings.

There has to be a space above the water to allow steam to be raised so, insert the end of the plastic pipe into the boiler and withdraw 30ml of water with the syringe. Replace the safety valve finger tight.

### **3) LUBRICATION**

Regular lubrication of all working parts is important and should be carried out before each operating session.

There are two types of lubrication required: The external moving linkages and bearings are lubricated with a medium oil such as motor engine oil, and the internal steam mechanisms such as cylinders, pistons and valves are lubricated with a special steam oil that is mixed with the steam. Infrequent external lubrication will allow parts to run dry, and over oiling can form pools around operating parts that attract dirt and grit. If too thin an oil is used it will evaporate very quickly as the loco gets hot, leading to dry

running. We recommend the use of a 20-50 motor oil for external lubrication.

Internal lubrication is achieved by steam oil that is mixed with the steam in the displacement lubricator, housed in the left-hand side of the cab. Remove the knurled cap from the top and slacken the drain screw two or three turns at the bottom but do not remove it. Any water in the lubricator will run out through the drain screw. Tighten the drain screw and refill with the steam oil supplied, then replace the cap.

Take time filling the lubricator, especially when cold, as the oil takes time to run down and may trap an air bubble. Both cap and drain screw are fitted with 'O' rings and need only be closed finger tight.

**NOTE:** Only special steam oil as supplied should be used in the lubricator and under no circumstances should ordinary oil be substituted, or damage may result.

The gas and steam regulators will require periodic lubrication  
– see the troubleshooting section for details.

#### **4) LIGHTING THE BURNER**

**WARNING:** Before lighting read the 'Gas System' section further on in this booklet, and be aware of potential problems. If the gas system is not operating correctly, **shut it off immediately** or damage may result.

Move the locomotive to another location before lighting. Butane is heavier than air and small pockets of gas can collect around the locomotive during filling.

To light the burner, hold a lighted match or cigarette lighter over the top of the chimney and **slowly** open the gas regulator by turning it anti-clockwise. The gas should ignite almost immediately with a



pop as the flame travels down the chimney and into the boiler tube. The burner should be audible but not too loud.

**NOTE** as stated above, the gas regulator should be opened slowly until the burner ignites. If opened too quickly, particularly when the engine is cold or if the gas tank has just been filled, it is possible that the flame may not travel back into the boiler flue but stay in the smokebox. If this should happen, the burner will sound quite different to normal and the blue flame will be visible in the smokebox if viewed down the chimney from a safe height. Should this happen, turn off the gas immediately or damage may result and then re-light it.

If the problem persists and it is not possible to ignite the burner correctly, then a dirty jet should be suspected and cleaned as in the Gas System Troubleshooting Section.

For the first couple of minutes keep the burner on low. This is important, as until it warms up, the flame will be a little unstable and turning it up too much could cause it to go out. Also, with a completely full tank, liquid gas could be drawn off instead of vaporized gas, which can also extinguish the flame.

After a couple of minutes, the gas control valve can be opened more to speed up steam raising. Open the gas regulator slowly to about one full turn.

The full range of adjustment (closed to fully open) is achieved within the **first full rotation** of the gas regulator knob any more is unnecessary.

## **RUNNING THE LOCOMOTIVE**

When full working pressure has been reached (about 40psi), the safety valve will start to blow off steam. Steam generation can be controlled by the gas valve in the cab. If the safety valve blows off

frequently during running, then too much steam is being produced, which wastes water and gas. Turning down the burner will decrease the amount of steam created. Conversely, if steam pressure is not maintained during a run, then the burner should be turned up. After a few minutes of running it may be noticed that the gas pressure through the burner has increased. This is due to the gas tank becoming warmer and so increasing the gas pressure. Simply turn the gas down – this may need to be performed several times during a run. The art of balancing steam generation to the operational requirement by the adjustment of the gas control valve will quickly be learned.

The gas tank has a duration of about 25 minutes, though this will vary a little depending on gas valve setting. The boiler should not be allowed to run dry, and the gas tank capacity is such that the gas should run out before the water. When the gas is fully used up, the steam pressure in the boiler will be seen to gradually drop until the loco comes to a halt. Should the water expire before the gas is fully used, the pressure will drop rapidly and the loco will stop. Check the pressure gauge – if this is zero turn off the gas. No damage will result if the gas is turned off immediately.

## **DRIVING THE LOCOMOTIVE MANUALLY**

On manually controlled locomotives, there are three main controls, all of which are housed in the cab.

1) The gas regulator, which should be used to control steam generation as described earlier.

2) The reversing lever. This is in the left-hand side of the cab and is moved fully forward for running in a forward direction and full back to run in the reverse direction. It should be parked in the centre (mid gear) when the locomotive is stationary for any length of time. When in mid gear position, the valve gear is effectively in neutral and the engine will not move under steam power.

3) The regulator. This is the main steam control valve and regulates the speed of the locomotive. The regulator handle is situated in the right hand cab doorway and is moved anti-clockwise to open and clockwise to close.

Using the reversing lever, select the desired direction of travel and open the regulator a little. Initially, there will be a certain amount of water in the pipes and cylinders, which will exhaust through the chimney and, after a few moments, the engine will move jerkily, until this clears. Once the parts have warmed up, the engine will move off steadily and its speed can be controlled with the regulator. Subsequent starts will be quite smooth once the cylinders etc. have reached their normal operating temperature.

To reverse the locomotive, close the regulator to bring it to a halt, move the reversing lever over and open the regulator again.

The art of fine control will soon be learnt with a little practice.

## **DRIVING BY RADIO CONTROL**

This model is fitted with 2.4 GHz R/C equipment. On a Radio Controlled model, speed and direction are controlled by the transmitter. First, turn on the transmitter and then switch on the receiver on the locomotive with the switch in the tender. The left hand stick on the transmitter controls the steam regulator, down for stop up for go. Moving to the left or right has no function.

The right hand stick operates the reverser, left for forward and right for reverse. This stick is sprung loaded to return to its central position. Moving up or down has no function

Using the transmitter, select the desired direction of travel and then slowly open the regulator. The locomotive will now move off as described in the manual control section.

For more information see the manufacturer's instruction booklet supplied with the Radio Control Set.

The art of fine control will soon be learnt with a little practice

**NOTE:** Ensure that the valve gear is fully in gear for the required direction when the engine is moving. The model is fitted with a simplified Walschaerts type valve gear which is not suitable for 'notching up' (altering the cut off). Always bring the locomotive to a halt by closing the regulator before changing direction. If an emergency stop is required, simply release the reversing lever, which will spring back into mid gear and halt the train. Then close the regulator. Always ensure that the regulator is closed before switching off the transmitter.

Always switch off the receiver and transmitter when not in use to preserve battery life. It is good practice to switch on the transmitter before the receiver and switch off the receiver before the transmitter. In this way, the radio receiver should always be under your control.

When the batteries are getting low, a poor signal between transmitter and receiver will result and control of the engine will become erratic. Refer to the instructions supplied with the radio control equipment.

## **STORAGE BETWEEN OPERATING SESSIONS**

At the end of an operating session, it is good practice to clean the locomotive carefully with a clean soft cloth, and to oil all bright metal parts.

- \* Do not leave fuel or water in the tank or boiler for long periods.
- \* Do not store in places where the temperature may drop below Freezing as water may still be present in the pipework.
- \* Ensure all controls are closed and the valve gear in mid gear.
- \* Ensure that radio control equipment is switched off and, if the Engine is not to be used for some time, remove all batteries.

Periodically it may be necessary to wash off all traces of dirt and old oil from the moving parts with paraffin (not thinners). This will

remove any accumulations of dirt or grit. After washing with paraffin, leave to dry thoroughly overnight before re-oiling. It is most important that clean oil is applied and allowed to penetrate fully into all moving parts before the locomotive is run again. Manually moving the locomotive back and forth will assist in distributing the oil fully. Under normal operating conditions this procedure should not be required more than once or twice per year.

### **ALTERING WHEEL GAUGE**

The wheels are set at the factory for the specified gauge however, for those who wish to alter this to run on other people's railways or if you change the gauge of your track, they are easily reset by using a Gauge Conversion Kit, which is available separately.

The driving wheels are moveable on their axles and are locked in place by a small grub screw. They should be adjusted so that the "back to back" gauge supplied in the kit will just slip between their inner faces. Ensure that the wheels are evenly spaced relative to each side frame. Do not over tighten the grub screws particularly on insulated wheels.

The tender wheels and axles are swapped for those of the required gauge by simply removing the keeper plate from the underside of the tender frame (two self tapping screws).

### **TROUBLE SHOOTING & MAINTENANCE**

On a working model of this nature, it is important to keep all working parts well lubricated. With constant heating up, cooling down and the stresses of hard work, screws etc. can work loose so, it is good practice to check all fixings and cylinder screws regularly but remember, never over tighten.

### **STEAM LEAKS**

With constant heating up, cooling down and the stresses of hard

work, screws etc. can work loose so, it is good practice to check all fixings and cylinder screws regularly but remember, never over tighten. The cylinders are fitted with 'O' rings in the glands sealing both piston and valve rods. These can be adjusted with a spanner if steam leaks develop. They should only be tightened just enough to stop the leak, as over tightening will affect running.

### **REGULATOR NOT SHUTTING (R/C models)**

The steam regulator seating and seal can, after a period of time become worn or compressed so that when the lever on the radio control is fully closed, the locomotive still moves. To overcome this, a trimmer is fitted to the transmitter. This is the small lever at the side of the main control lever and is set at the factory to the top of its slot. As wear takes place in the regulator, it can slowly be moved down the slot to compensate. When it reaches the bottom, it is time to reset it to the top and adjust the linkage between the servo and the regulator in the cab. If adjustment does not cure this problem, the internal 'O' ring is probably damaged and requires replacement. Contact the factory for further advice.

Periodic oiling of the gland will help keep the regulator working freely. Place a spot of motor oil between the gland nut and the regulator arm and work the regulator a few times.

### **RADIO CONTROL**

If the radio control gives problems, always check the batteries first and replace if in doubt. AA size batteries are used, both in the locomotive and in the transmitter. For further details of the Radio Control equipment, refer to the manufacturers literature supplied.

### **GAS SYSTEM**

Internally fired locomotives are fitted with our 'FG' type gas burner, which is set up and fully tested at the factory. This system is designed for use with Butane or Iso-Butane gas. Mixed gasses, i.e. Butane with a proportion of Propane mixed in, are available, and may be used if straight Butane is unavailable. These come in a

variety of mixes ranging from 90/10 to 60/40 with one of the most common being 70/30. The figures refer to the proportions of the mix i.e. 70/30 contains 70% butane and 30% propane. If using mixed gasses, always choose the one with the largest proportion of butane. The addition of propane slightly alters the gasses properties. This can make the burner a little more difficult to light when cold or after filling the gas tank. Always open the regulator very slowly when lighting, and only just sufficient for ignition to take place. Opening too much too soon may extinguish the flame until the burner reaches normal operating temperature.

The tiny jet in these units can become blocked by small particles of dirt making the burner difficult to light, burn weakly at normal operating temperatures\*, burn in the smokebox or fail completely. If any of these should happen, clean out the jet as follows. (\* On very cold days, a burner may start off burning weakly due to the temperature of the gas but should increase to its normal level as the engine warms up. This is quite normal) .Carefully, disconnect the gas pipe from the gas jet holder using a 2BA spanner.

**Note** when connecting or disconnecting the gas pipe and jet block, do not use excessive force. Always hold the end of the gas burner near the air holes to support it otherwise it is possible to cause damage by bending the body.

Slacken the screw retaining the gas jet holder and slide it out to the rear. Remove the jet from the gas jet holder using a 4BA spanner. Wash out the jet in fast evaporating thinner (Cellulose or similar). Blow through the jet from the front, which should clear most blockages. Although the hole through the jet is tiny, if you hold it up to the light you should be able to see quite clearly if it is blocked or not. If in doubt, fit a new jet. A spare gas jet is included with the toolkit. Do not use wire to clean the jet as this can damage the precision hole and may upset the delicate balance of the gas system. Reassemble in the reverse order, putting a small amount

of PTFE tape round the thread of the jet. Ensure all connections are tight. When re-positioning the gas jet holder in the burner, ensure that it is pushed in as far as it will go. The gas regulator has a spindle 'O' ring housed inside the body which may need lubrication from time to time if the control becomes 'spongy' in operation, making precise gas control difficult.

As stated in the lighting instructions the full range of adjustment for normal burner operation is achieved within the first full rotation of the regulator knob, and it should only be unscrewed more than this for maintenance purposes and when the tank is empty, and there are no naked lights nearby.

To lubricate it, remove the knurled knob which is retained by a M3 socket grub screw in the side. Beneath the knob is a back-lash spring and white PTFE washer which will slide off the spindle. Unscrew the hexagon retaining nut then screw the spindle out of the body. The 'O' ring can now be lubricated. Replace the spindle followed by the retaining nut. Slide the white PTFE washer and backlash spring over the spindle and replace the knob. Note that the grub screw that holds the knob in place tightens into a groove near the end of the spindle.

---

### Gas Regulator (Internal Parts)

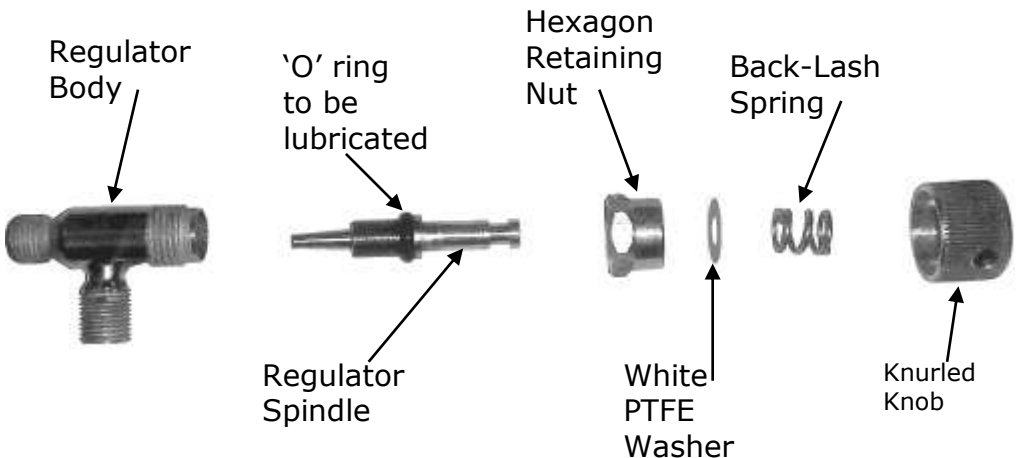



ROUNDHOUSE

**ROUNDHOUSE  
ENGINEERING  
CO.**

EC

**De**

**St**

**eam  
m  
Ge  
ner  
ato  
r**

**Ves-**

Mo

**sel for  
Group  
1 gas-  
ses and  
associ-  
ated  
pipe  
work and  
fittings.**

Si

**R. Lo**

Dated

Please refer to the 'owners handbook' for your particular model of locomotive, for details on correct use of these pressure vessels.

## **Pressure vessel care and maintenance**

### **Gas tank**

The gas tank is used for the storage of LPG (liquefied petroleum gas) in the form of butane, iso-butane or as set out in the 'owners handbook'.

The tank is fitted with a self-venting filler valve which contains no serviceable parts. Should the filler valve become defective in any way, it must be replaced with a new item.

It is recommended that the gas tank should undergo the following checks, carried out by a 'competent person', club, society or pressure vessel manufacturer, every year:-

- 1) thorough visual inspection.

And every five to ten years:-

- 1) hydrostatic pressure test to not less than 1.5 and not more than 2 times the maximum working pressure.

### **Boiler**

The boiler is fitted with a safety valve to prevent the steam pressure rising above the maximum allowable working pressure. This is pre-set to open at between 2.38 bar (35 psi) and 2.72 bar (40 psi) and must not be adjusted to increase this value. If the safety valve becomes defective in any way, it should be replaced or returned to the factory for service and calibration.

It is recommended that the boiler should undergo the following checks, carried out by a 'competent person', club, society, or pressure vessel manufacturer, every one to two years:-

- 1) thorough visual inspection.
- 2) hydrostatic pressure test to not less than 1.5 and not more than 2 times the maximum working pressure.
- 3) steam test to check the correct functioning of all steam controls, gauge and safety valve.

## Gas Burner

- 1). Superheater Pipe.
- 2). Lubricator Pipe.
- 3). Gas Jet Holder retaining screw.
- 4). Gas Jet.
- 5). Gas Jet Holder.
- 6). Gas Pipe.
- 7). Gas Burner fixing screw.
- 8). Air Inlet Holes.

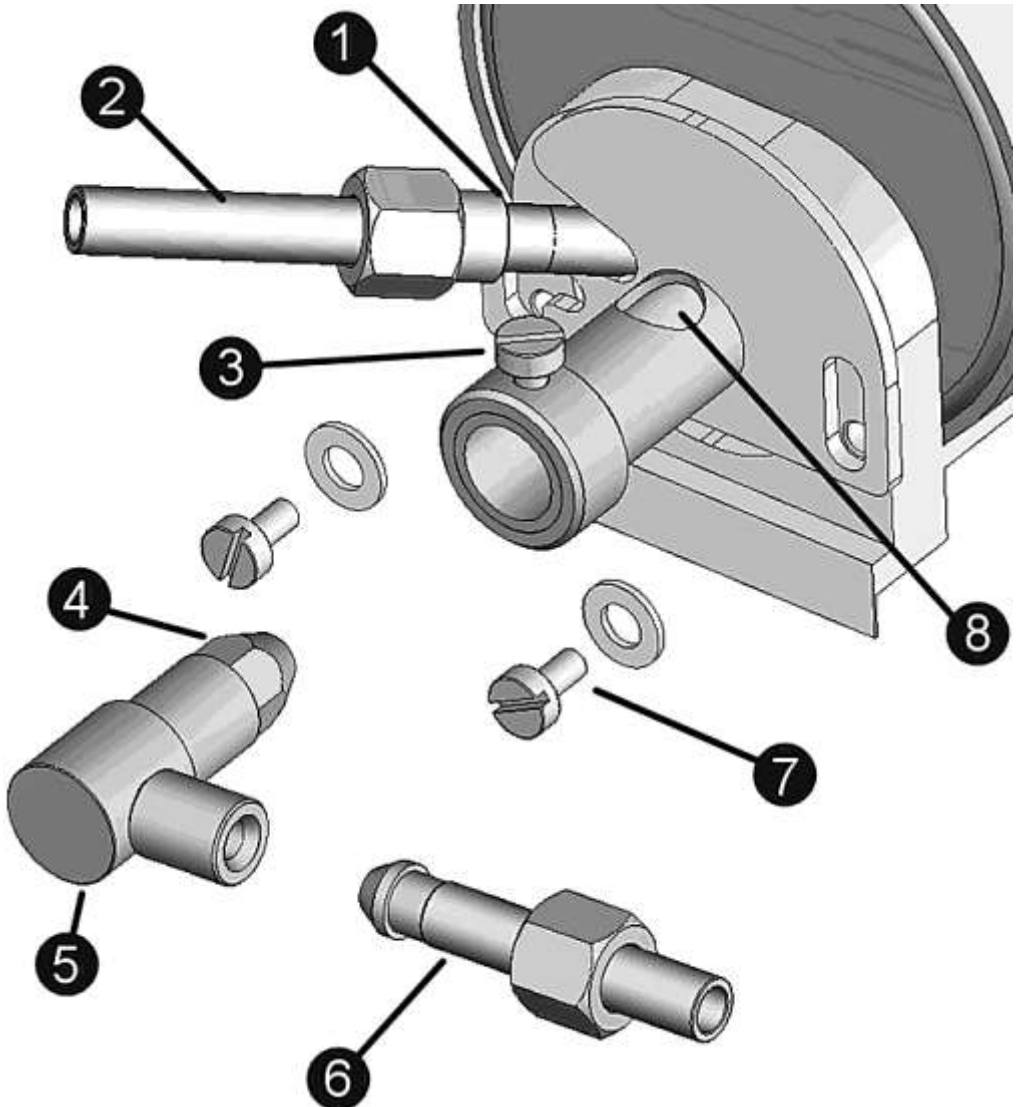

## SERVICE AND PARTS

If any problems arise with this model which are not covered in these operating instructions or, spare parts are required, owners should first contact their local dealer. Your **ROUNDHOUSE** dealer is;



If your dealer is unable to help, please contact the Factory directly:

### **ROUNDHOUSE ENGINEERING CO. LTD.**

Units 6-10 Churchill Business Park. Churchill Road.

Wheatley. Doncaster. DN1 2TF. England

Telephone: 01302 328035 Fax: 01302 761312

Email: [mail@roundhouse-eng.com](mailto:mail@roundhouse-eng.com)



**ONLINE**

**[www.roundhouse-eng.com](http://www.roundhouse-eng.com)**