

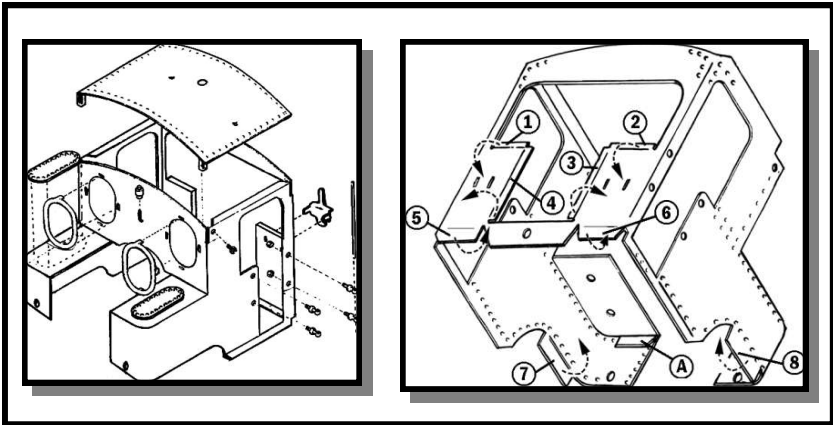

# Modular Locomotive System

## Instruction Manual for HBK5 Billy Body Kit



**Roundhouse Engineering Co. Ltd.**

Unit 6-9 Churchill Business Park

Churchill Road, Wheatley

Doncaster. DN1 2TF

ENGLAND

Tel. 01302 328035

Fax. 01302 761312

Email: [support@roundhouse-eng.com](mailto:support@roundhouse-eng.com)



**ONLINE**

[www.roundhouse-eng.com](http://www.roundhouse-eng.com)



# **HBK5 BODY KIT FOR 0-4-0 CHASSIS AND BOILER.**

## **INTRODUCTION**

These instructions cover the construction of the body kit intended to fit the HBK1 & HBK3 chassis and boiler kits.

All parts are included to build the locomotive as the factory built 'Billy'.

The brass panels are photo etched to shape and all fold lines and holes are etched into the parts where necessary.

Only a minimum of cleaning up is required and will normally simply mean running around the edges with a small file or emery cloth. As a general rule, all folds should be 90 degrees with the etched lines on the inside of the angle except if specifically stated otherwise.

The kit is designed for either manual or radio control operation and all fixing holes are provided for both versions.

The panels have been designed for assembly with soft solder, however, if preferred holes can be drilled at the joints and small rivets or screws used. If soldering, a small to medium butane blow torch is ideal as the large area's of brasswork will dissipate the heat of a soldering iron too quickly unless a very powerful one is used. Use a suitable flux with the solder, Bakers fluid being particularly good, though extreme care must be taken during use. Follow the manufacturers instructions on the packaging at all times. Glue of any kind is not suitable for the main structure, but is required for such items as the tank fillers, etc. 'Araldite', 'Devcon' or a similar epoxy adhesive are ideal for this purpose.

Refer to diagrams where necessary and hold parts together with small clamps such as toolmakers clamps or miniature G clamps, during soldering or drilling of joints. It is advisable to run through the full instructions identifying all parts and mountings and have a 'dry run' before soldering anything in place.

All painting is left to the builder and there is a good choice of colours available in both cellulose or enamel. Spray paints will give a much better finish and can be obtained from your local

DIY shop or motorist accessory centre in aerosol cans. A good primer is essential and if available an etch primer should be used on brass parts. A good model shop will stock more specialised paints and should include etch primer in the range. Read carefully and follow the makers instructions that appear on the can before using any paint. All parts must be thoroughly cleaned and rubbed down with fine wet and dry paper prior to painting.

## LIST OF CONTENTS

1	Cab floor
1	Cab body panel (folded)
1	Cab front panel
1	Roof
1	Body tank support
2	Boiler bands
1	Brass dome
1	Cast brass sand dome with 10BA Brass screw
2	Brass spectacles (oval)
1	Brass dummy sanding lever
1	Roof hinge
1	Servo mounting bracket
2	Brass lamp brackets
2	Cast dummy tank fillers
1	Dummy whistle
1	Whistle mounting bracket
1	Brass sand dome cap
8	Brass handrail knobs
4	Brass handrails
2	8BA x 1/2" Brass screws
3	6BA x 3/16" brass screws
2	6BA brass nuts
2	8BA x 3/16" brass CSK screws
4	8BA x 1/4" brass screws
16	8BA nuts

## CAB LAYOUT

This diagram below shows the layout of the cab fittings on the finished model, having previously constructed the HBK1 and HBK3 kits.

The version shown is manual controlled.

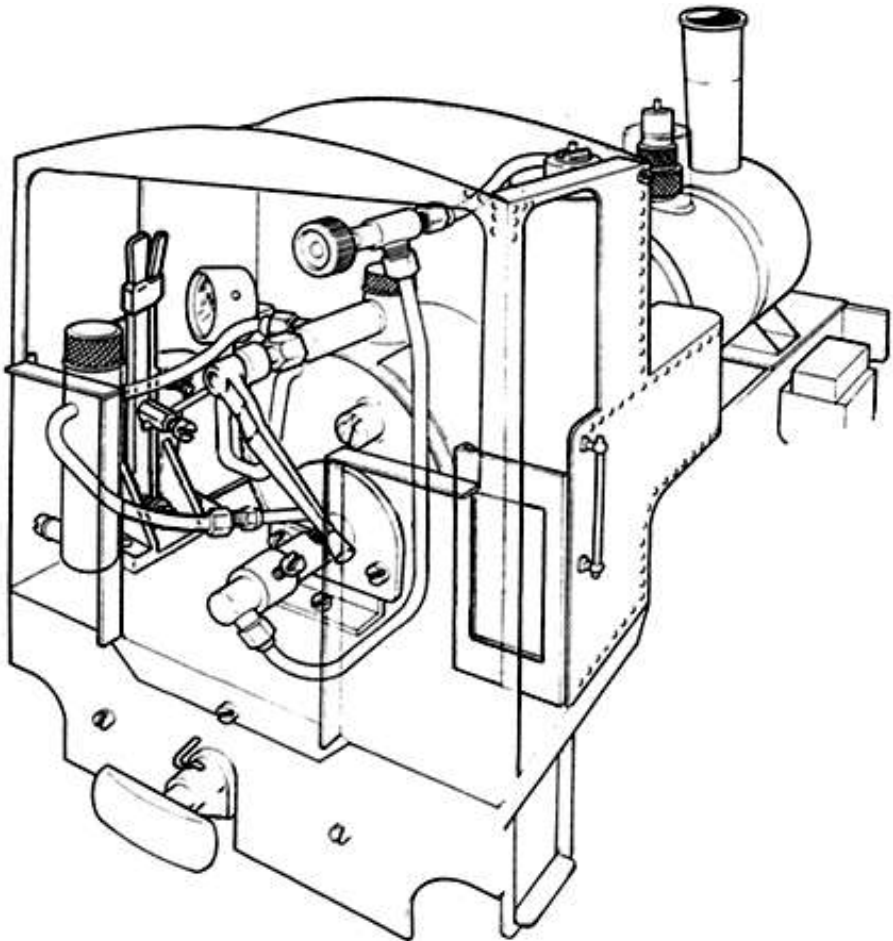

## CONSTRUCTION.

If you have already constructed the boiler kit HBK3, one boiler band and the boiler wrapper will already be fitted to the boiler. We now need to fit the remaining two boiler bands around the boiler wrapper. If the chassis/boiler is complete, it will be necessary to remove the lubricator, gas tank and gas burner.

Unscrew the two union nuts that connect the lubricator to the regulator and superheater. The lubricator can now be put to one side. Unscrew the union nut that connects the gas pipe to the gas regulator. Remove the two screws that attach the gas burner to the back of the boiler bracket. The gas burner can now be removed and also placed to one side. Remove the two screws and locknuts that hold the gas tank to the chassis enabling the gas tank to be removed.

Unscrew the 6BA fixing screw that attaches the rear of the boiler to the rear frame spacer and remove this screw and the spacers underneath.

The boiler can now be pulled backwards out of the smokebox - the cab end of the superheater may need to be straightened slightly if the boiler does not easily slide over the superheater.

The two boiler bands may now be fitted using 8BA x 1/2" screws and nuts - refer to the diagram and instructions on the following page.

## BOILER BANDS

The boiler band nearest the rear of the boiler should be only loosely fixed in place. When the body is fitted later on, it may be necessary to adjust the position of this boiler band to align with the cab front. The final position of the boiler band screws should be to the underneath of the boiler.

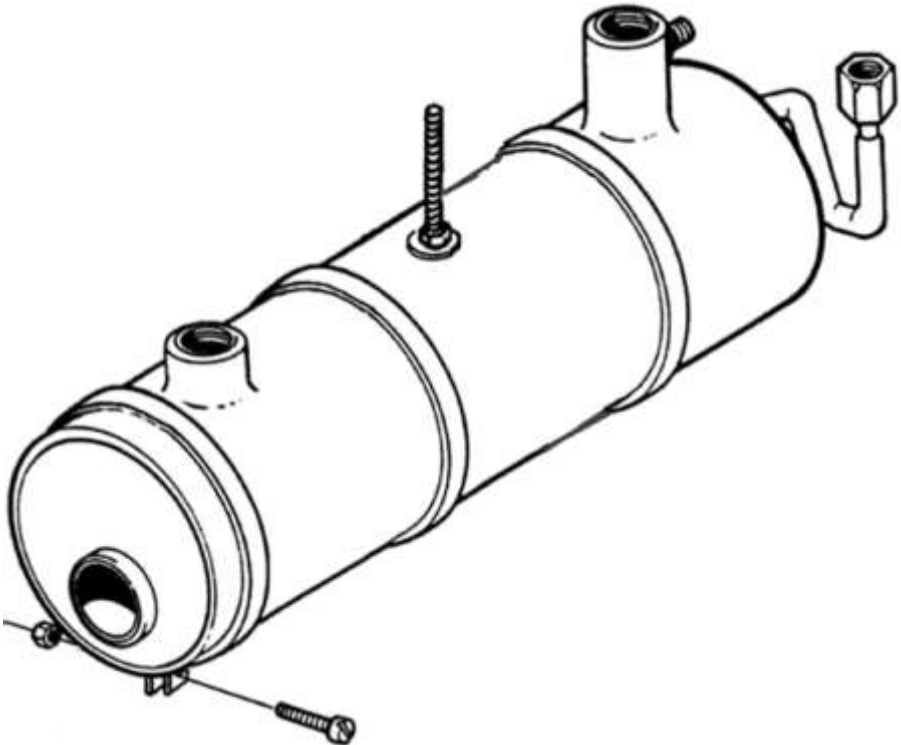

*DIAGRAM SHOWING POSITION OF BOILER BANDS.*

## FOLDING LONG SECTIONS OF BRASS

When folding long brass sections such as the side flanges of the cab floor, it is better to hold the flanges between two pieces of angle iron in a vice or clamps, as illustrated below. In this way, all the flange is bent over in one movement and results in a much neater finish.

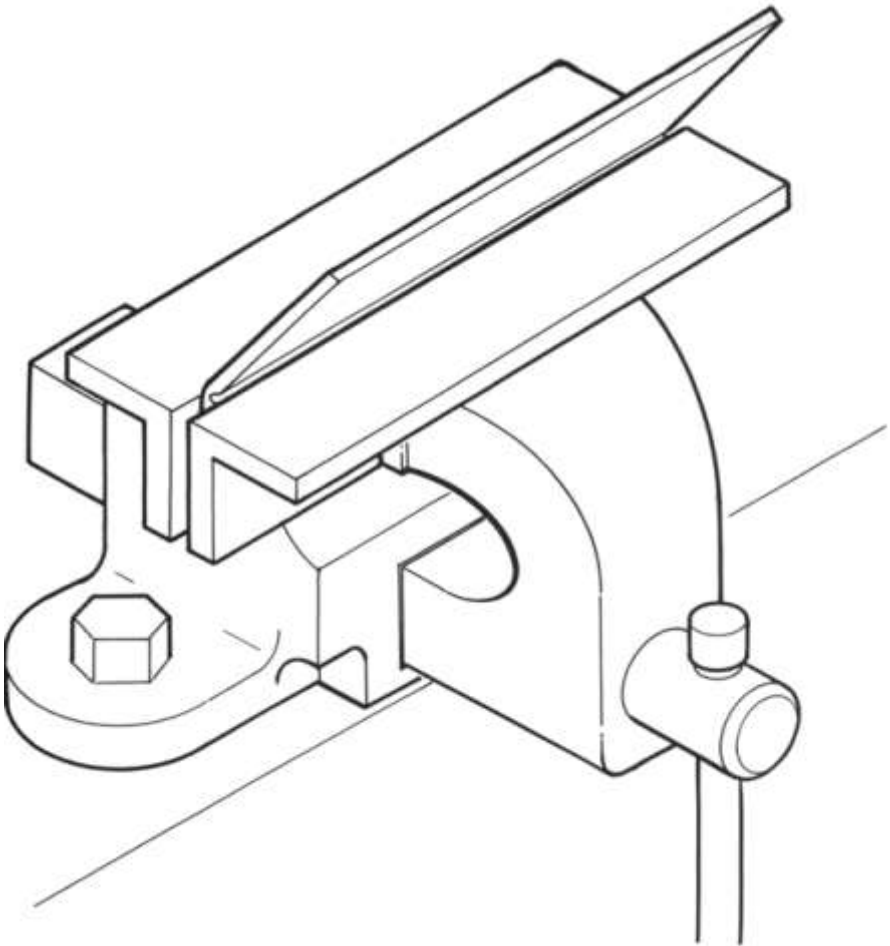

## CAB FLOOR

Before the cab floor is fitted, it must first be folded.

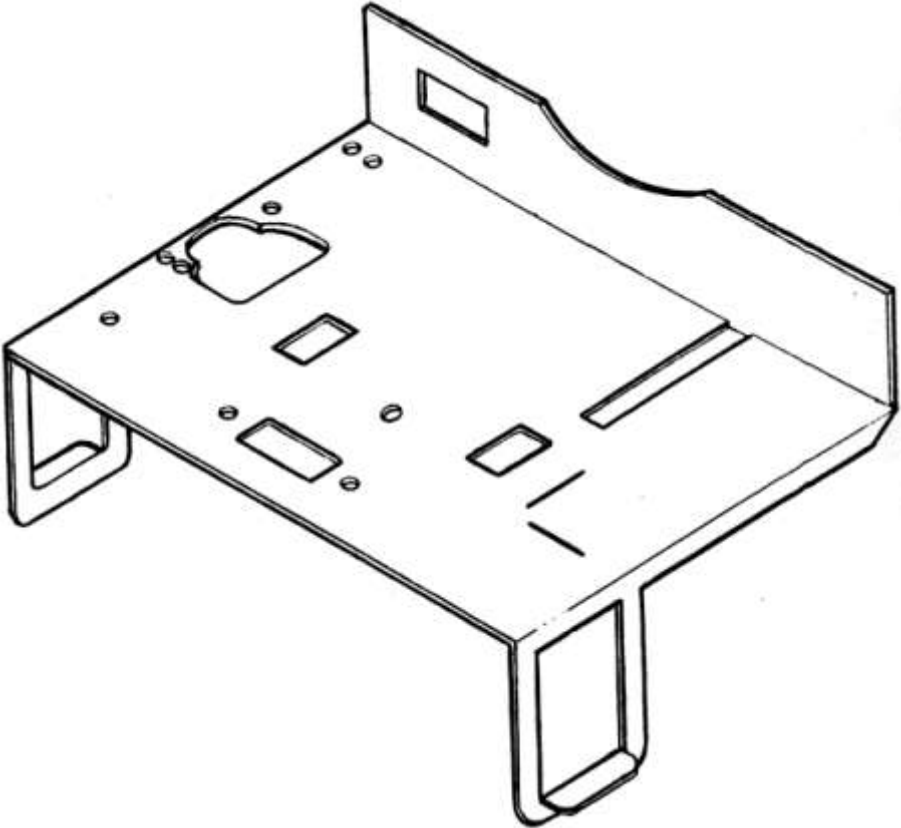

When folded into shape, the cab floor should appear as shown in the diagram above. Ensure that the **ROUNDHOUSE ENGLAND** logo that is etched into the brass remains to the top when finished.

Fold the front of the cab floor 90° so it points upwards at a right angle.

The flanges and cab steps should now be folded downwards at 90°, and the lip towards the bottom of the step folded outwards to form the step.

If you intend to radio control the model later, the bracket that will hold the cab servo can be fitted. It should be bent and fitted to the cab floor as shown below. The tags on the bottom fit through the slots in the cab floor. These tags can then be bent over underneath and soft soldered to the cab floor.

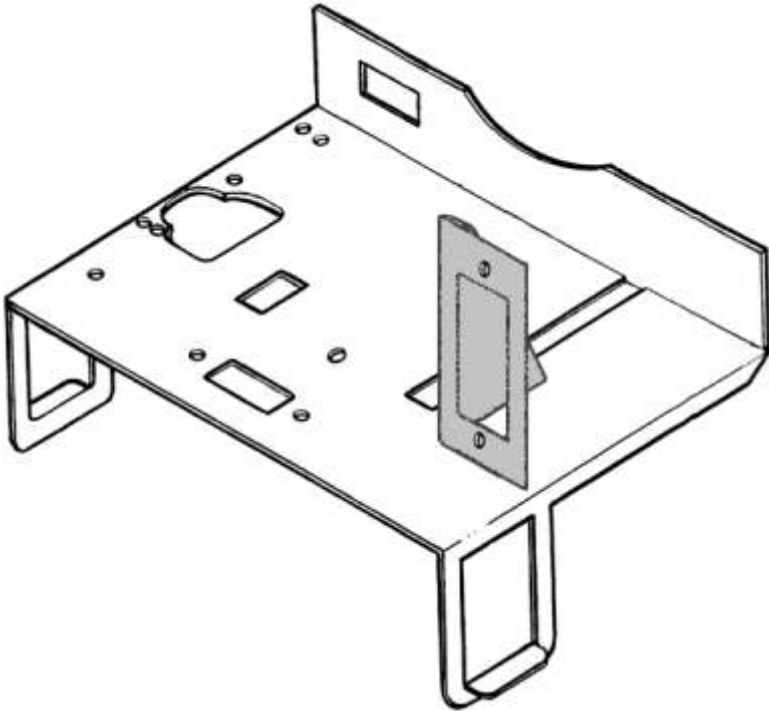

The floor can now be painted and fitted to the chassis. Lay the cab floor on the chassis so that the rear edge of the floor is level with the rear buffer beam and the hole in the frame spacer is visible through the hole above the ROUNDHOUSE logo.

The boiler can now be refitted using the 6BA screw and spacers removed earlier. Check that the rear boiler band is forward of the cab floor. The thickness of the cab floor may make it necessary to remove a spacer to ensure that the boiler remains level.

The gas tank may now be refitted. There is a slot in the cab floor that allows the gas tank mounting bracket to pass through. It is attached to the chassis as before using the two 6BA brass screws and locknuts.

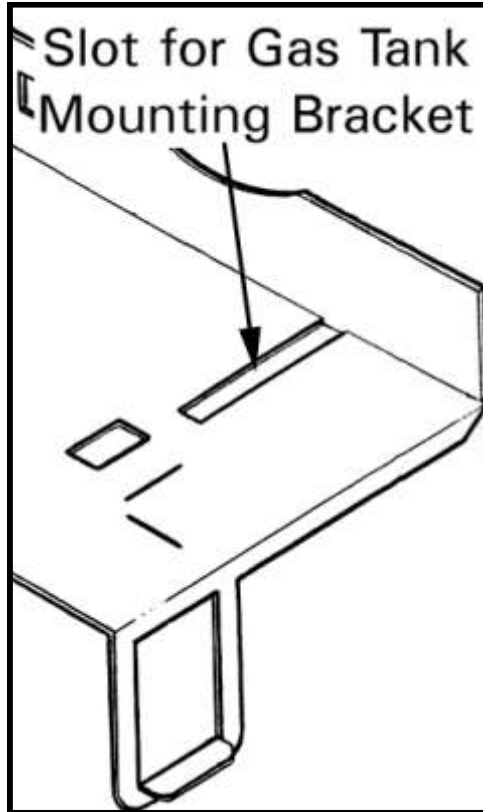

The gas burner should now be replaced using the two brass screws. The gas pipe should now be reconnected to the gas regulator. The pipe may require bending slightly to avoid the servo bracket.

The reversing lever may now be fitted to the cab floor with its brass screws through the holes identified below.

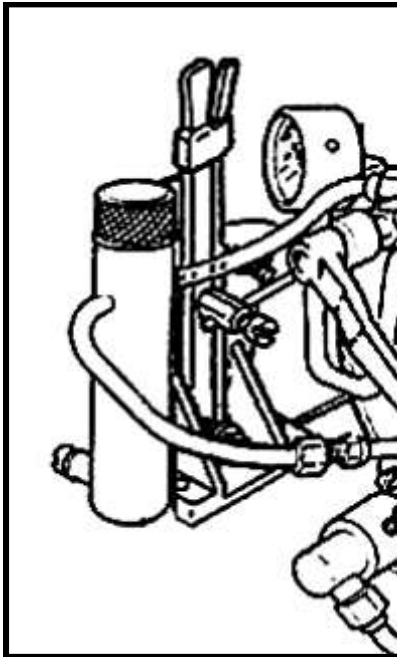
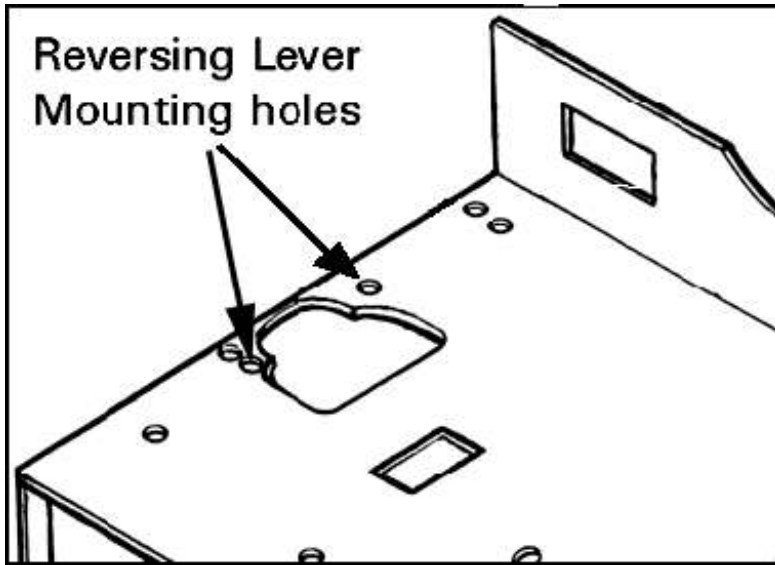

Refit the lubricator. It should be positioned centrally above the cab step, with the drain screw overhanging the cab floor slightly. Ensure that the lubricator pipe that connects to the superheater does not protrude over the rear buffer beam as this will foul the body when we come to fit this later.

## CAB BODY

We will now start to work on the main body. Quite a lot of folding is required, and you will remember from the introduction the general rule regarding this:-

*all folds should be 90 degrees, with the etch lines on the inside of the angle except where specifically stated otherwise.*

Bearing this in mind, fold the 8 panels numbered 1 to 8 in the diagram below. Panels 1 to 4 are folded outwards whilst panels 5 to 8 are folded inwards.

The radius at the front of the two side tanks is pre-formed. The tag at the front of each side tank top (shown as A on the diagram below) is folded down inside the tank and will be soldered into position later on.

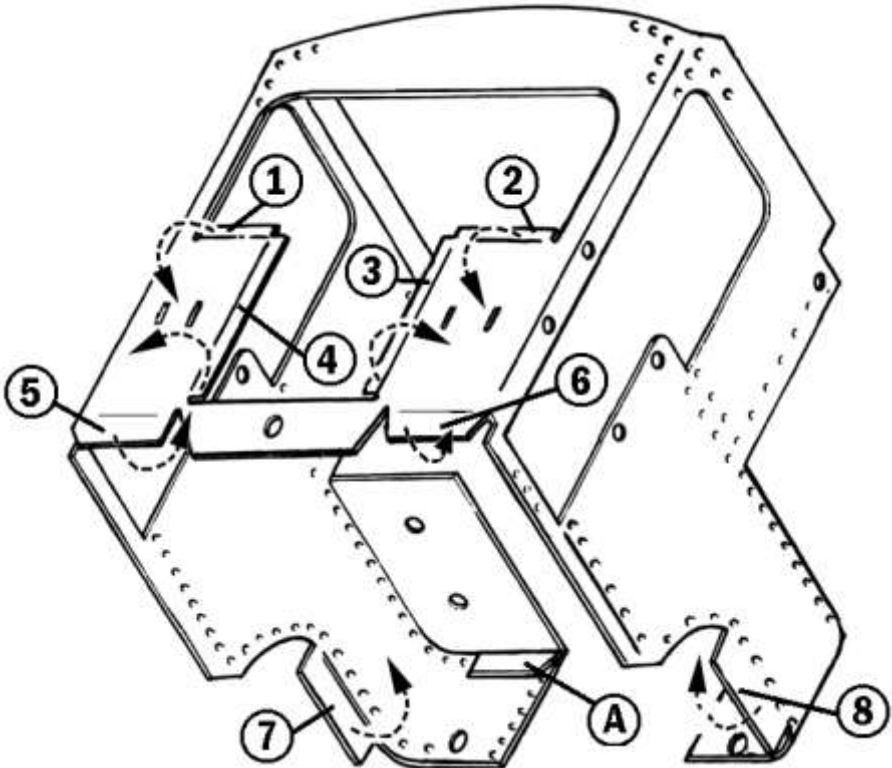

## CAB FRONT

Here there are 4 tags to fold. The 2 tags at the bottom fold forwards and the tags on either side fold to the back. Again fold into the etch line so that all tags are at right angles to the cab front.

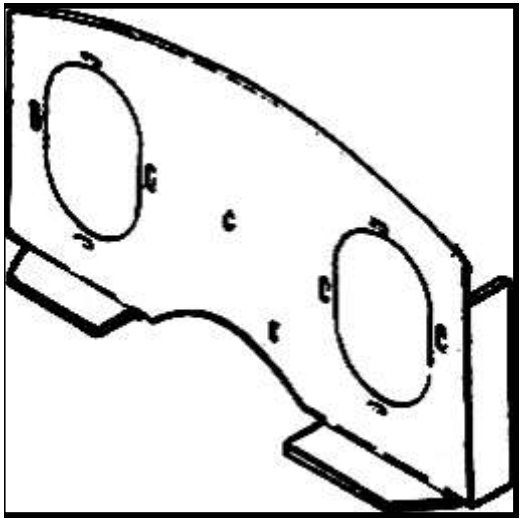

Fold the lamp brackets as shown in the diagram to the left below. The side tabs can then be pushed through the rear of the body in the slots provided as shown in the diagram on the right. The tabs can then be bent over and should be soldered inside the cab later.

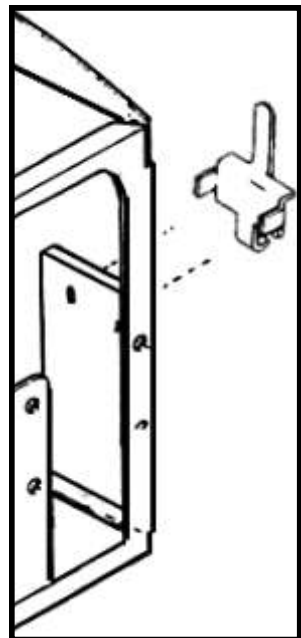
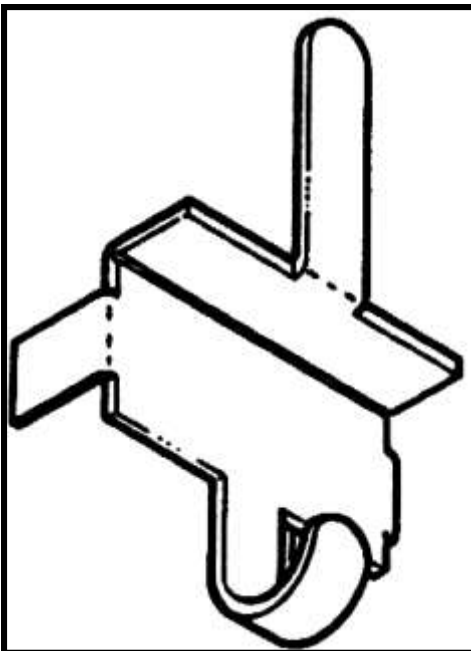

## SOLDERING

Slide the cab front up into the main body, as shown in the diagram opposite. Clamp tag 1 on the cab front to the side panel. Clamp tag 2 to the underside of the side tank .

Tag 3 is in the side tank and should be clamped to the front of the tank. Check that all joints are held square before soldering.

Now repeat this procedure for the 3 tags on the other side. The lamp brackets can also be soldered into place.

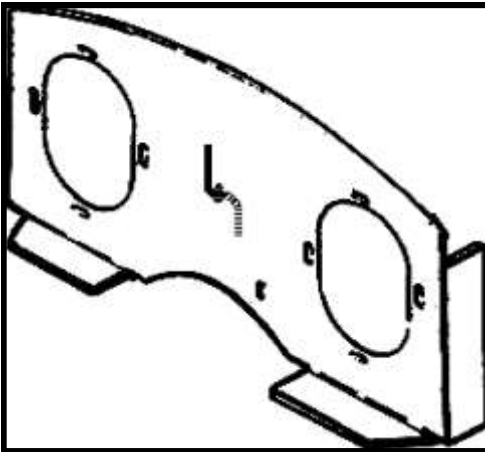

The whistle bracket (fixing rod) fits through the hole in the centre of the cab front. Push the rod through from the front until the first bend in the rod is reached. Gently twist the rod until the front is sitting in the correct position. Clamp the rod inside the cab, check that it is square and solder into place.

The dummy tank fillers can now be glued to the top of the side tank. This is shown on the diagram on page 17.

The body can now be prepared and painted as outlined in the introduction.

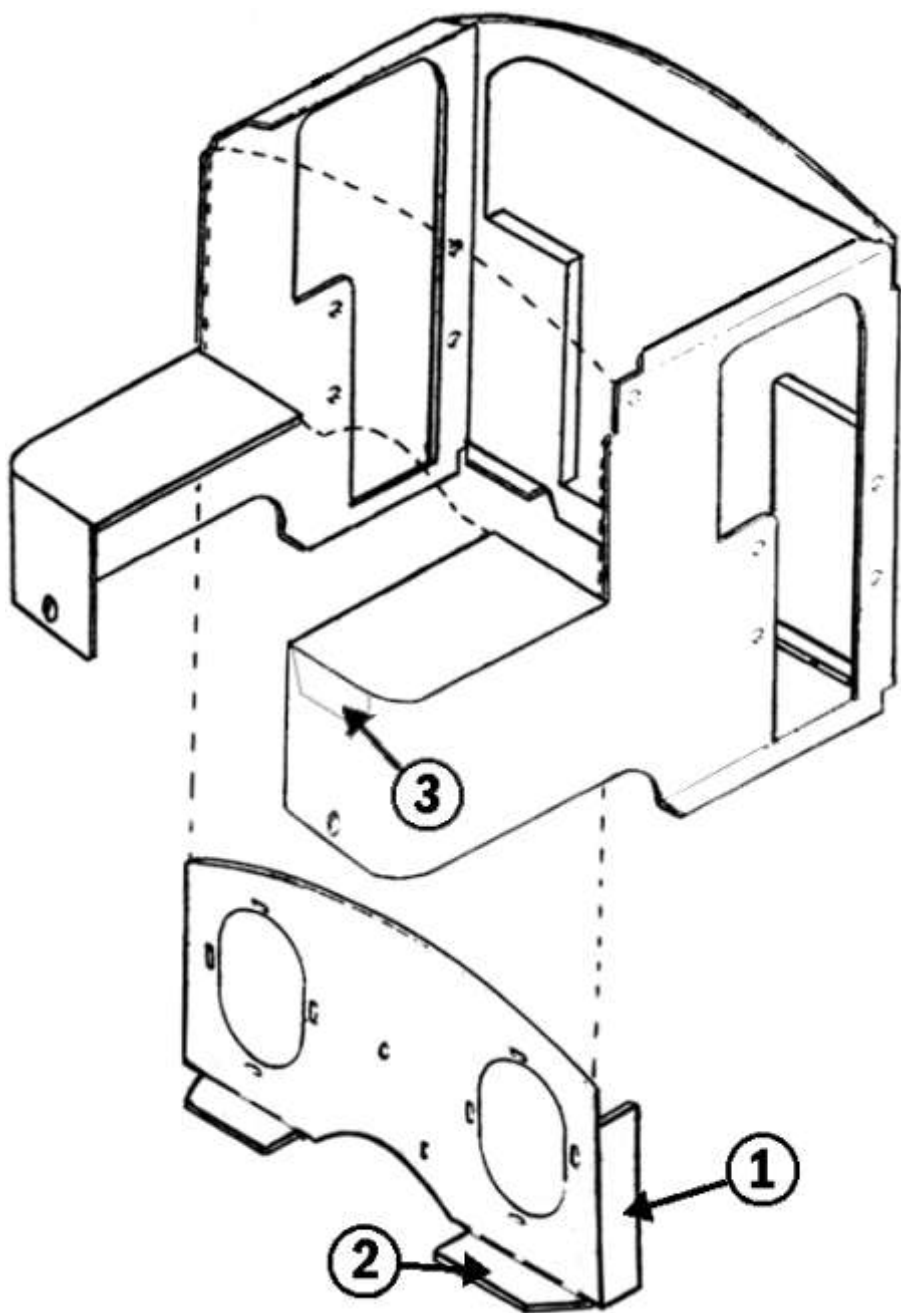

## ROOF

Fold the cab roof hinge as shown in the diagram below, and attach it to the underside of the cab roof using two 8BA countersunk screws and nuts. The hinge has slotted holes to allow for adjustment of the roof position. After tightening into position, file away any excess thread. The roof may now be painted.

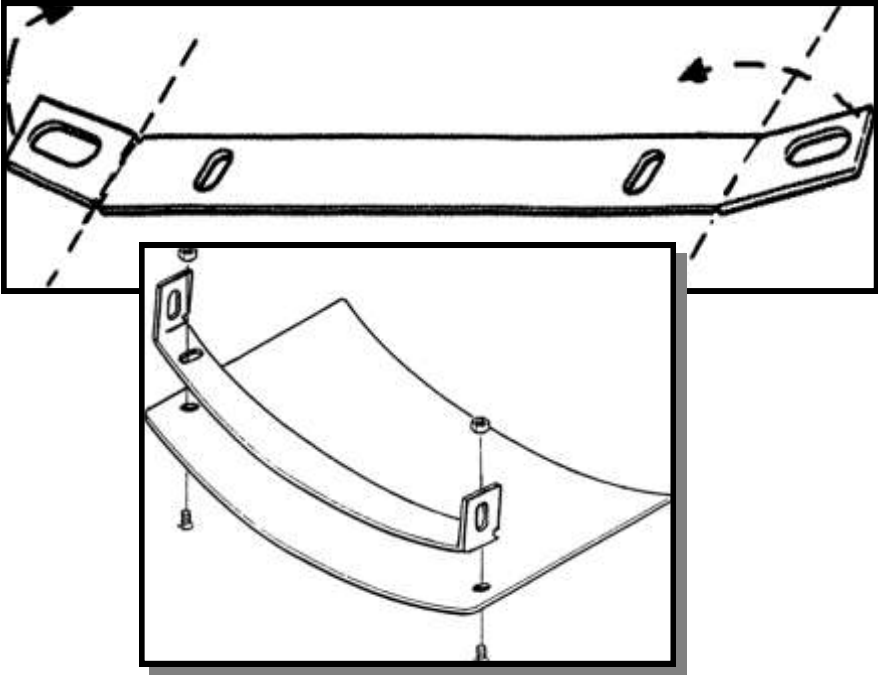

## BODY FITTINGS

When the body is completely dry, spectacles, handrail knobs and handrails can be fitted.

The four tags on the spectacles should be folded as before at right angles. The spectacles can now be fitted to the cab front by pushing the tags through the slots provided. The tags are then simply bent over on the inside. They do not require soldering or gluing. The eight handrail knobs should be fitted as shown in the

diagram opposite. They are secured with 8BA nuts from the inside. It is easier to fit the handrails into the handrail knobs if they are left slightly loose at this stage. Slot a handrail through the holes in the top and bottom handrails, check that it is positioned correctly and tighten up the 8BA nuts. Usually they will hold in place perfectly well, but if they do become loose they can be secured by glue or Loctite 601.

The whistle may now be glued onto the top of the whistle bracket at the front of the cab.

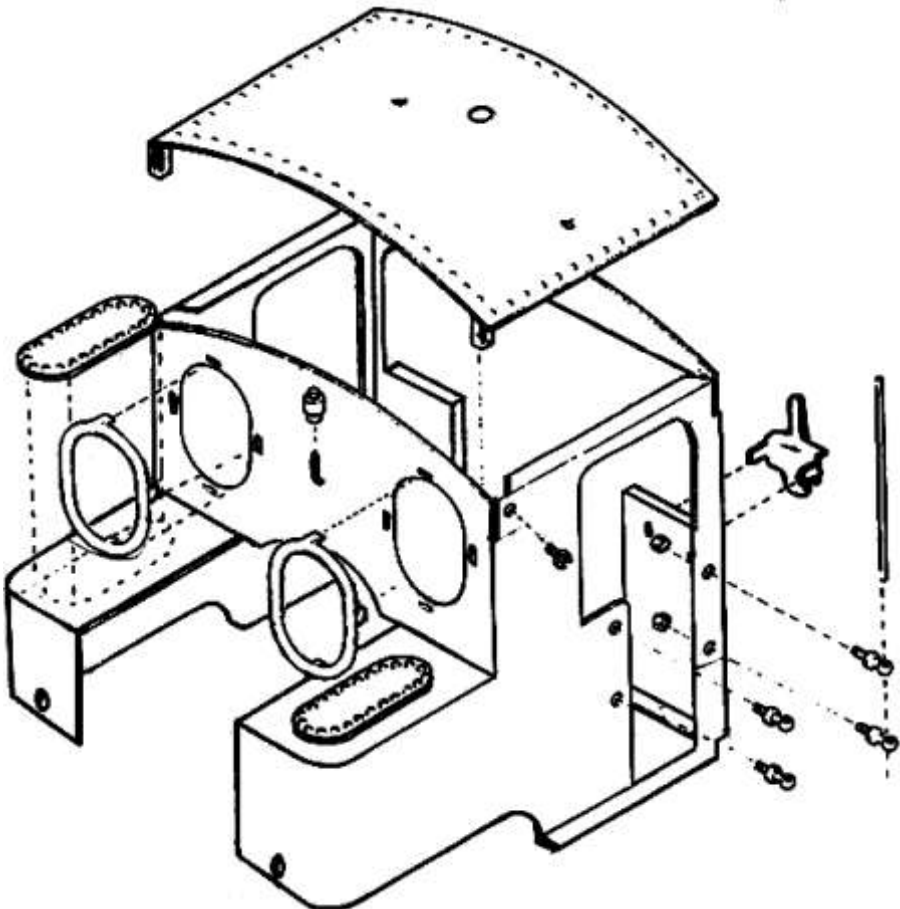

Before fitting the body, the reversing lever should be connected to the lifting arm. The rod should be bent at an angle of around 20° approximately an inch from the lifting arm. This is necessary to avoid fouling the side tank when the body is fitted. Pull the lifting arm backwards into reverse gear and pull the reversing lever fully backwards. Check the length of rod needed and remove any excess. The rod may now be connected to both the reversing lever and lifting arm and checked to ensure even movement.

### **FITTING THE BODY**

The completed, painted body can now be fitted. Carefully place the body over the gas tank and lubricator. The left hand side may need to be eased over the lubricator drain. Check that it is square and seated correctly all round. A 6BA x 3/16" brass screw should be used to secure the bottom rear of the cab to the rear buffer beam.

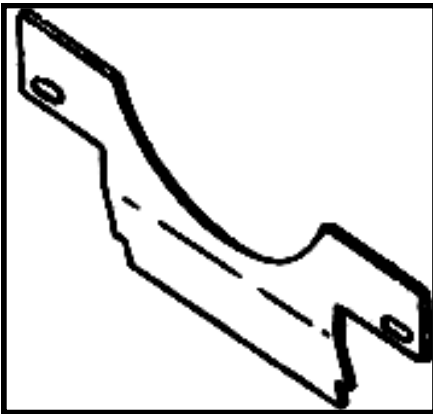

The tank support should now be fed under the boiler to the inside of the side tanks. Using 8BA screws and nuts, attach the cab support to the side tanks. but do not tighten up yet. When the cab support is fitted, check that the side tanks are level and then tighten the screws up fully to hold in place.

The cab roof is attached by an 8BA screw and nut at either side. These screws both pass through from the outside with the nuts on the inside and should be left

slightly loose to allow the hinge to operate. A spot of 'Loctite' or, if this is not available, paint on the threads will prevent the nut from coming off.

The dummy brass sanding dome can be slotted over the 4BA brass screw in the centre of the boiler. Check that the side with the tapped hole is to the left. The pipes should be just forward of the side tanks, and can be carefully bent into position if necessary. The brass cap screws down onto the protruding thread. A small amount of the thread may need to be removed by careful filing to allow the cap to tighten onto the sanding dome. The sanding dome lever fits into the slot in the cab (shown below), and screws into the tapped hole using the 10BA screw provided.

Finally, the brass dome simply sits over the safety valve assembly.

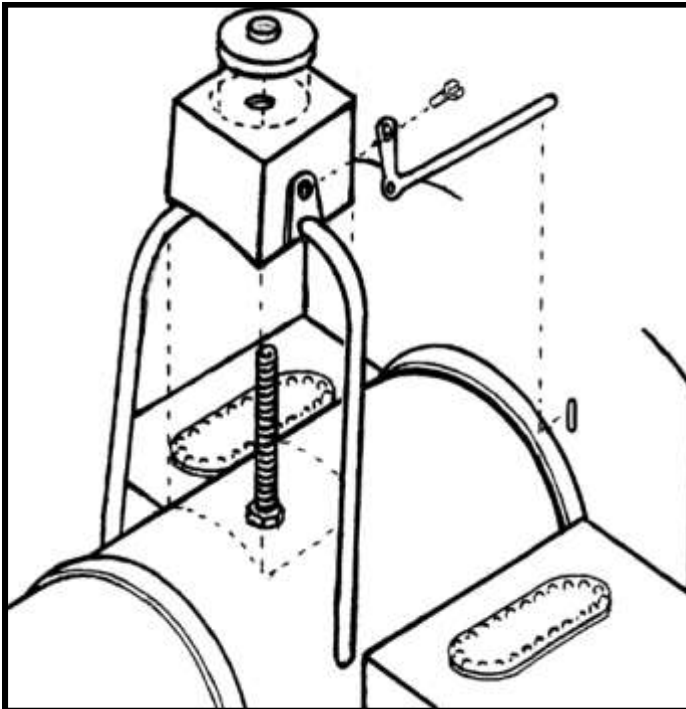

## **HBK5 CHECKLIST**

### **Billy Body Kit**

- 1 Cab body panel (folded)
- 1 Cab floor
- 1 Cab front panel
- 1 Roof
- 1 Body tank support
- 2 Boiler bands
- 1 Brass dome
- 1 Cast brass sand dome with 10BA Brass screw
  
- 2 Brass spectacles (oval)
- 1 Brass dummy sanding lever
- 1 Roof hinge
- 1 Servo mounting bracket
- 2 Brass lamp brackets
- 2 Cast dummy tank fillers
- 1 Dummy whistle
- 1 Whistle mounting bracket
  
- 1 Brass sand dome cap
- 8 Brass handrail knobs
- 4 Brass handrails
- 2 8BA x 1/2" Brass screws
- 3 6BA x 3/16" brass screws
- 2 6BA brass nuts
- 2 8BA x 3/16" brass CSK screws
- 4 8BA x 1/4" brass screws
- 16 8BA nuts

**Checked**