

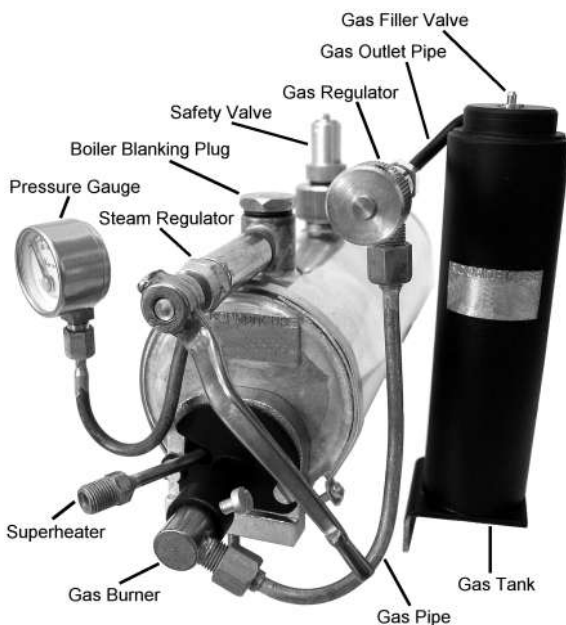

**Modular Locomotive System**

# **HBK3 Billy Boiler Kit**

## **Instruction Manual**



### **ROUNDHOUSE ENGINEERING CO. LTD.**

Units 6-9 Churchill Business Park. Churchill Road.

Wheatley. Doncaster. DN1 2TF. England

Telephone: 01302 328035 Fax: 01302 761312

email: [support@roundhouse-eng.com](mailto:support@roundhouse-eng.com)



**ONLINE**

**[www.roundhouse-eng.com](http://www.roundhouse-eng.com)**



## HBK3—Gas Fired Boiler and Fittings

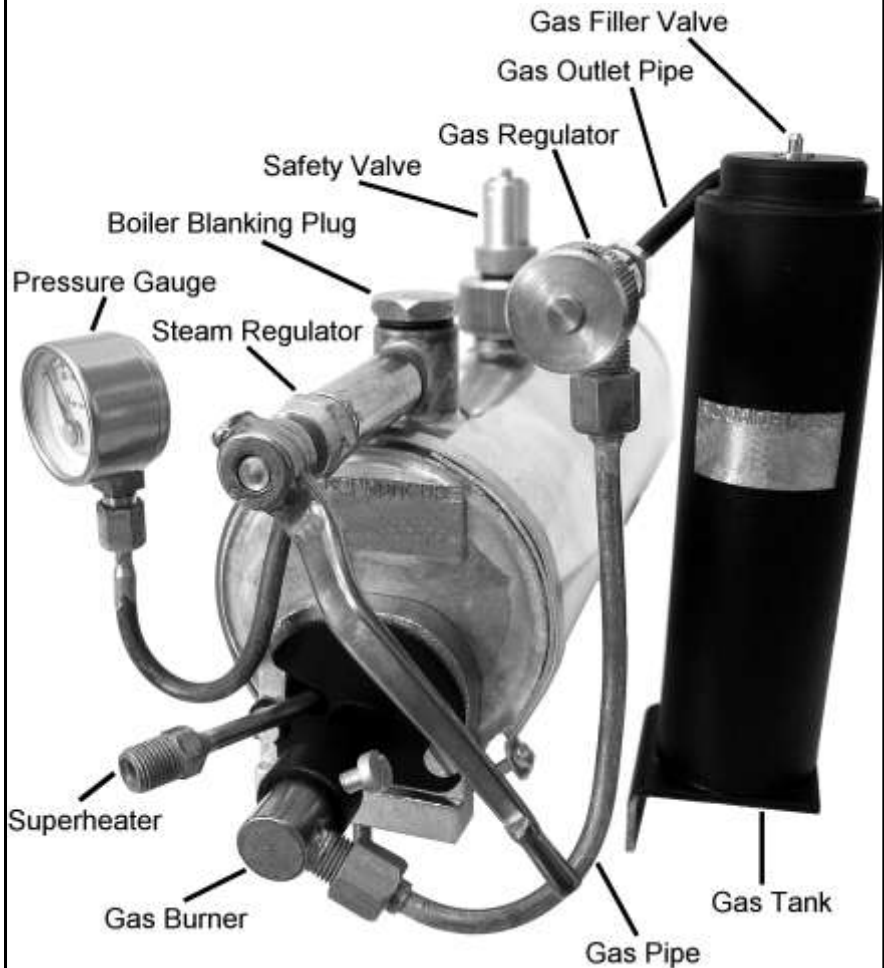

## HBK3 Gas Fired Boiler and Equipment

These instructions cover the installation of a gas fired boiler to the HBK1 Walschaerts valve-gear 0-4-0 chassis kit. Before starting to actually assemble these parts, read through these instructions fully so that you identify all parts and understand where each is fitted. Refer to diagrams at all times as these will make it clear which way round certain parts go.

Before starting assembly, refer to the checklist on the back page, and check that all parts are included.

## Cab Layout

This diagram shows the layout of the cab fittings on the finished model fitted with Walschaerts valve gear for manual control. Note that the bodywork and cab floor shown in the diagram are not included in this kit, but are available in the HBK5 body kit.

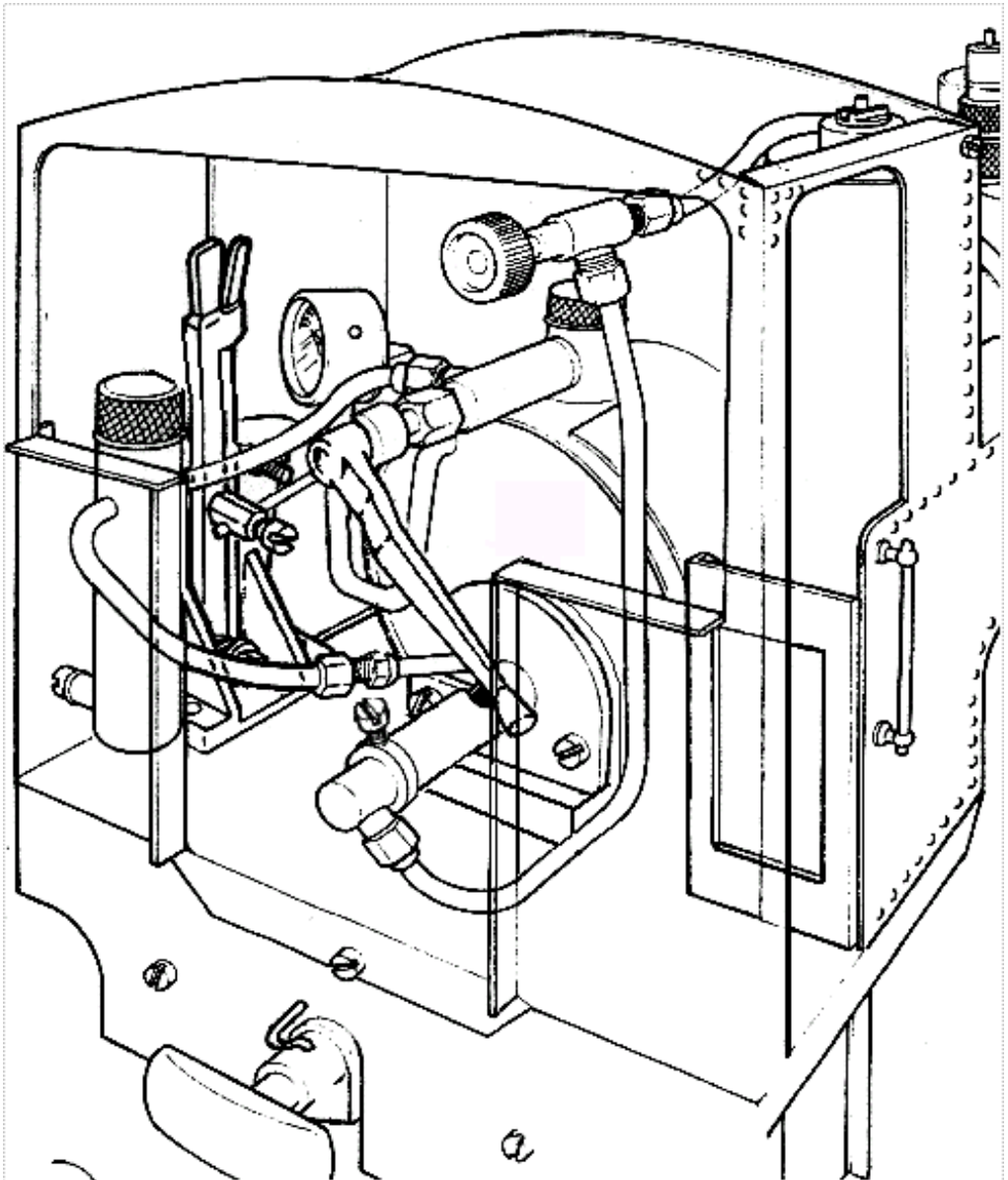

# Construction

## **BOILER AND STEAM FITTINGS**

Before fitting the boiler, all fittings have to be removed .

Unscrew and remove the safety valve. This will enable the brass wrapper to slide forwards and off the boiler. The steam fittings (regulator and pressure gauge) can now be removed. These are just loosely screwed on for ease of packing.

The brass wrapper can be painted the desired colour at this stage. The brass should be thoroughly cleaned and rubbed down with fine wet and dry paper before painting. Cellulose or enamel paint is readily available in spray cans for a good finish but a primer must be used first.

Etch primer and compatible top coats are available from more specialised modellers' suppliers that are more suitable for use on brass and can give a more durable finish.

The Smokebox assembly also requires cleaning and painting before fitting to the chassis. Cellulose or enamel paints will stand the heat pretty well, though for a more durable finish high temperature paint is available at motor spare shops. These come in aerosol cans and are intended for car engine and exhaust painting. Follow the manufacturers' instructions regarding storage and use.

After painting, the door handle (smoke box dart), can be fixed to the smokebox front by pushing the threaded part through, and securing in place with the nut supplied.

## **FITTING THE SUPERHEATER**

The main steam pipe (superheater) passes down the single flue of the boiler on its way to the cylinders to give a certain amount of re-heating to the steam. The superheater should be attached to the cylinder inlet pipes before the boiler and smokebox are fitted. These are then threaded over the pipe.

If you have already fitted your superheater as described in the HBK1 instruction booklet, move straight on to **INSTALLING THE SMOKEBOX**.

If the superheater is not yet fitted, please continue reading.

The superheater has a 'T' connector silver soldered to one end that connects the two cylinders. Carefully bend one of the steam inlet pipes up just a little. Slide one of the 2BA hexagon union nuts onto the steam inlet pipe followed by an 'O' ring. Next, slide on one end of the 'T' as far as it will go, and loosely screw the union nut onto it with the 'O' ring inside. The superheater should be pointing straight upwards for now. Push a union nut and 'O' ring onto the inlet pipe of the second cylinder as before. Now bend the first pipe down again until the open end of the 'T' will slide back over the second inlet pipe. Loosely screw the second union nut onto the 'T' then position it centrally between the frames and tighten up both union nuts just sufficient to squeeze the 'O' rings a little. Take care not to over-tighten or you will crush and damage the rubber 'O' rings. It may be necessary to remove the screws from the two front frame spacers on one side only to allow the frames to be eased apart slightly. This will give a little extra space or manoeuvring the 'T' onto its pipes. Remember to replace them before nipping up the union nuts.

In order to line up with the centre flue of the boiler, the superheater pipe requires bending. The bend should start approximately 30mm up from the 'T' so that the length of the superheater runs parallel to the chassis, about 20mm above it.

The two cylinder exhaust pipes can now be bent to shape. They should bend up around the front of the superheater 'T' and come together in the middle, pointing upwards side by side. These pipes are screwed into the cylinder block so take care when bending them not to snap the thread where it enters the cylinder block. Don't worry if the exhaust pipes appear slightly loose - they will be held in place when the smokebox is fitted.

### **INSTALLING THE SMOKEBOX.**

The smoke box sits over the bend in the superheater with the exhaust pipes positioned up into the chimney. Sit the smokebox on the chassis and secure with 3 M3 brass CH screws. The first screw fits through the front of the footplate and into the front frame spacer. The other two of these screws secure the rear of the smokebox into the second frame spacer, one on each side. Check that the exhaust pipes are pointing up the chimney side by side.

## **THE BOILER WRAPPER**

The square sandbox, available in the HBK5 body, kit sits on top of the boiler and secured by a screw that fits through the small hole in the top of the wrapper. Push the 4BA long brass CSK screw through this hole from underneath. Put the 4BA washer on the screw thread on top of the wrapper, and secure with the 4BA nut. This can be tightened into place. Slide the brass boiler wrapper back over the boiler, making sure that the cut-out fits around the steam dome, do not tighten it on yet.

## **THE BOILER & MOUNTING FOOT**

The boiler mounting foot, which is a steel casting, should be fitted to the back of the boiler now. The large hole in it fits over the flue tube, and the curved platform points forward and sits under the boiler barrel. One of the brass boiler bands should be fitted around the rear of the boiler over the boiler wrapper, passing over the curved platform, so that when tightened, it clamps the mounting foot to the boiler. Ensure that the boiler band is flush with the back edge of the boiler, and position the clamp screw near the bottom so that it does not foul the footplate or any other items. Before tightening the boiler band fully, ensure that the mounting foot is pushed up against the boiler backhead. Also, when the mounting foot is stood on a flat surface, the steam dome and boiler filler plug are standing vertical on top of the boiler. If not, simply rotate the boiler on the mounting foot until all looks OK.

The boiler is now slid over the superheater so that it passes right down the centre flue and out of the back. The front end of the boiler pushes into the smoke box until the hole in the boiler mounting foot lines up vertically with the hole in the rear frame spacer.

If fitting the HBK5 body kit, the cab floor can now be fitted as detailed in the body kit instructions. If however you do not have this kit or are building your own body, a brass spacer plate is provided to take its place and keep the boiler level.

Place the brass spacer plate (the thin brass plate approx. 1/4" wide with a hole in the middle), between the mounting foot and the frame spacer, then fix firmly with the M3 x 12 Brass CSK screw up through the frame spacer from underneath and into the tapped hole in the mounting foot. If you have a chassis kit prior to version 3, you

will need to drill out the 6BA tapped hole in this frame spacer for M3 clearance— 3.2mm, and countersink the hole.

Fit the second boiler band at the front of the boiler to the rear of the smokebox. Note that this boiler band does not go around the wrapper, but directly onto the boiler. The boiler wrapper can now be moved forward to meet the rear edge of the boiler band. The boiler band should be now sandwiched tightly between the smokebox at the front, and the boiler wrapper at the rear. Two further boiler bands are supplied in the HBK5 body kit, or can be purchased separately. Check to see that the boiler wrapper is aligned correctly and tighten up the two clamp screws underneath. The boiler band securing the mounting foot can now be tightened.

## **STEAM REGULATOR**

Fit the steam regulator to the rear of the steam dome on top of the boiler. It needs to finish up with the steam outlet on the side at about the 7 to 8 mark on a clock face when viewed from the rear and should screw on finger tight until it is about 45 degrees from the desired position. If it does not, the fibre washer can be reduced in thickness by rubbing it on a flat file until this is achieved. Now the regulator can be fixed in place using a little plumbers thread seal or PTFE tape, with the final 45 degree of rotation compressing the fibre washer a little to give a good firm seal. Do not force things, - this goes for all fittings, remember the threads are quite fine.

## **PRESSURE GAUGE**

The pressure gauge does not require sealing as the cone fitting takes care of this. It should be on the left hand side but final positioning can be done to suit the body when that is fitted. The copper siphon pipe to which it is attached is easily bent with the fingers, but this should be done with care. You will need two 4BA open ended spanners to tighten up the union nut.

## **SAFETY VALVE**

The Safety valve is simply screwed into the bush at the top of, and towards the front of the boiler until finger tight and is fitted with an 'O' ring seal. It is set to lift at approximately 40 psi.

## BOILER BLANKING PLUG

The boiler blanking plug is screwed into the turret at the top rear of the boiler. This makes use of a 'O' ring and needs only to be finger tight.

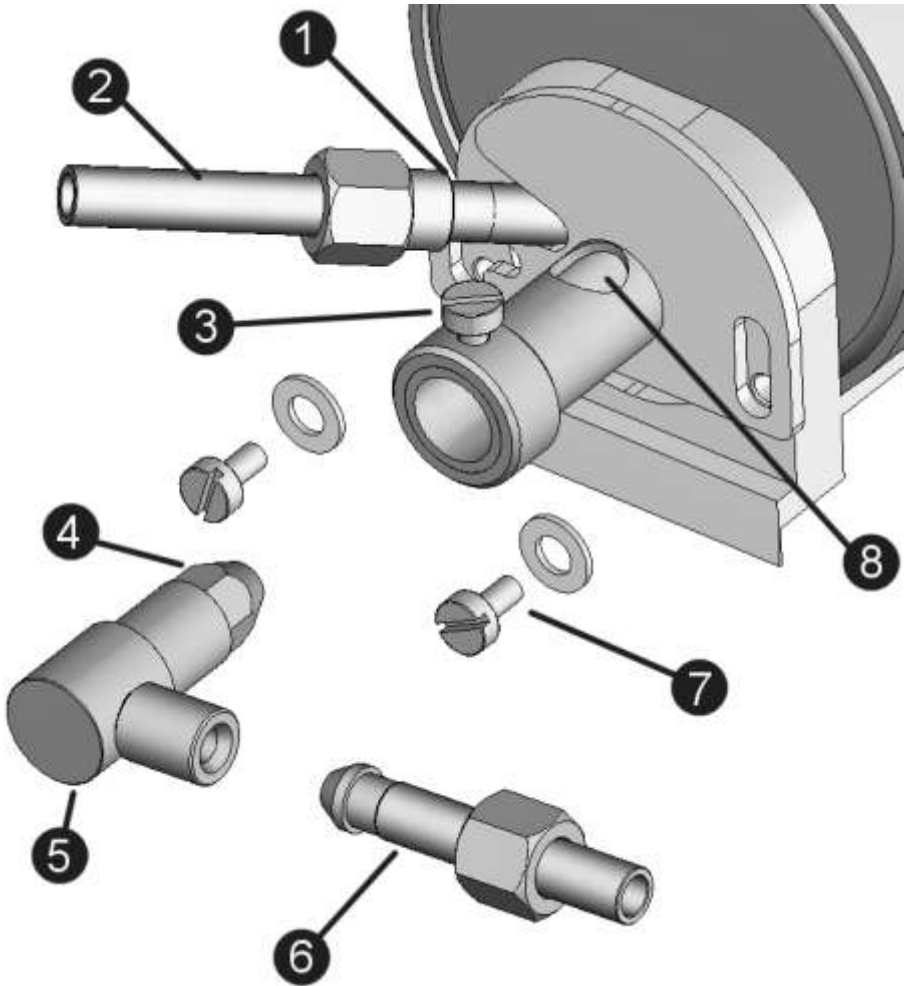

### ***Gas Burner***

- 1). Superheater Pipe. 2). Lubricator Pipe.  
3). Gas Jet Block retaining screw. 4). Gas Jet.  
5). Gas Jet Block. 6). Gas Pipe.  
7). Gas Burner fixing screw. 8). Air Inlet Holes.

## GAS SYSTEM

In line with all our locomotives, this boiler is now fitted with the ROUNDHOUSE "FG" type gas burner, which requires no adjustment other than initial positioning. The screw holes on the mounting flange are slotted to allow for this. The superheater pipe should pass down the centre flue to the left hand side and, on emerging from the back, should be bent over slightly to the left. A wedge shaped notch is cut out of the gas burner mounting flange to allow the superheater to pass through it. Ensure that the superheater is well over to the left hand side of the flue tube for its full length. Fix the burner to the mounting foot using the two screws and washers already fitted to the mounting foot. The washers are placed between the head of the screw and the face of the gas burner mounting flange. The burner should be set to the bottom of the flue tube and the right hand fixing screw is slotted vertically to enable this. This allows the maximum space above the burner for the gas to burn correctly.

**Note:** do not over tighten these screws.

Check that the jet is tight in the jet block (4BA spanner) then push the jet block into the burner body as far as it will go (up to the step in the jet block) before nipping up the retaining screw.

The gas tank is designed to fit in the right hand side of the cab where it can take advantage the radiated heat from the boiler to offset the temperature loss caused by the gas changing from liquid to gas. There **must** be a clear airspace between it and the boiler and under no circumstances should it be in contact with the boiler or other steam pipes and fittings. The base of the tank is fixed to an L shaped bracket which fits down the inside of the right hand frame just to the rear of the frame spacer/rear boiler mount. The two holes in the bracket should line up with two holes in the frame. Use two brass CH screws and nuts supplied with the gas tank to fasten the tank to the frame—the nuts are fitted to the inside of the frame.

## GAS REGULATOR

The gas regulator is mounted horizontally with access through the rear of the cab once the body is fitted (see diagram, page 3) The outlet pipe itself can be bent slightly if required to achieve final position but keep any such bending here to an absolute minimum or the pipe may be damaged.

The gas connecting pipe can be bent to shape by hand as shown in the diagram. If you re-site the tank to suit a different body configuration, you may need to make up your own pipe. Use 1/8" dia. copper pipe of a suitable length to reach from the regulator to the burner, avoid contact with other steam fittings or pipe-work. and any joints must be silver soldered.

## **CYLINDER LUBRICATOR**

We can now fit the cylinder lubricator to complete the steam fittings. This sits over to the left hand side of the cab as far back as possible, in the doorway. Final positioning is left until the body is fitted so for now, just bend the pipes by hand to place it roughly in position (see cab layout diagram).

Looking at the left hand side of the chassis with the lubricator drain facing you, the left hand pipe bends up and inwards to connect to the regulator and the right hand pipe bends round the back of the lubricator and forwards to connect to the end of the superheater pipe where it emerges from the flue tube.

## **Preparing the chassis for running**

You should now be in a position to test run your chassis and make any adjustments or final fixings to the valve-gear as detailed in the chassis instructions (e.g. pinning the return cranks on Walschaerts valve-gear).

## **LUBRICATION**

Regular lubrication of all working parts is important and should be carried out before each operating session. There are two types of lubrication required: The external moving linkages and bearings are lubricated with a medium oil such as motor engine oil, and the internal steam mechanisms such as cylinders, pistons and valves are lubricated with a special steam oil that is mixed with the steam. Infrequent external lubrication will allow parts to run dry, and over oiling can form pools around operating parts that attract dirt and grit. If too thin an oil is used it will evaporate very quickly as the loco gets hot – leading to dry running. We recommend the use of a 20-50 motor oil for external lubrication.

Internal lubrication is achieved by steam oil that is mixed with the steam in the displacement lubricator, housed in the left-hand side of the cab. Remove the knurled cap from the top and slacken the drain screw two or three turns at the bottom but do not remove it. Any water in the lubricator will run out through the drain screw. Tighten the drain screw and refill with the steam oil supplied, then replace the cap. Take time filling the lubricator, especially when cold, as the oil takes time to run down and may trap an air bubble. Both cap and drain screw are fitted with 'O' rings and need only be closed finger tight. **NOTE:** Only special steam oil as supplied should be used in the lubricator and under no circumstances should ordinary oil be substituted, or damage may result.

The gas and steam regulators will require periodic lubrication – see the troubleshooting section for details.

### **FILLING THE BOILER**

The boiler is filled through the boiler bush into which the safety valve is screwed. A syringe and short length of plastic pipe are supplied. Remove the safety valve and fill the boiler right to the top with clean water. Distilled water is recommended if available. As an alternative to distilled water if this is unavailable, clean tap water can be used in soft water areas. Also, rain water or water from a dehumidifier can be used provided that it is adequately filtered. Do not use deionised water as this type of water may cause long term damage to the boiler and fittings. There has to be a space above the water to allow steam to be raised so, insert the end of the plastic pipe into the boiler and withdraw 30ml of water with the syringe. Replace the safety valve finger tight.

### **FILLING THE FUEL TANK**

The filling of the gas tank should only be carried out in a well-ventilated area, where there are no naked lights or other lighted locomotives close by. Ordinary Butane or Iso-butane gas (as used in gas cigarette lighters) is the preferred fuel, though for economy, the larger canisters as used for blowlamps or camping stoves etc. are better. The larger canisters require a special adapter to couple up to the filler valve on the locomotive and some brands are supplied with a small plastic adapter which does this job. If however one is not available, a special brass adapter is obtainable from your

local garden railway supplier or direct from **ROUNDHOUSE**.

Mixed gasses are also available and may be used if ordinary butane or iso-butane are not available, but see 'Gas System' on page 15 for more information on this subject.

Before attempting to fill the gas tank, make sure that the gas control valve is closed by turning it clockwise and that there are no other operating locomotives or naked flames nearby.

The filler valve for the gas tank is the coal bunker on the right hand side and is accessed by lifting out the dummy coal load. Ensure that the gas canister is fitted with a correct adaptor then invert it and place its nozzle over the gas filler valve. Support the locomotive from underneath in the area of the tank, and press the canister down. The gas will be heard hissing as it enters the tank and a small amount will escape around the valve. This is quite normal and is the tank venting as the liquid enters. After about 20 to 30 seconds, liquid gas will emerge from the valve showing that the tank is full. Remove the canister immediately. Filling times will vary depending on the temperature of the locomotive and are for guidance only.

## **LIGHTING THE BURNER**

**WARNING:** Before lighting read the section on gas system troubleshooting and be aware of potential problems. If the gas system is not operating correctly, **shut it off immediately** or damage may result.

Move the locomotive to another location before lighting. Butane is heavier than air and small pockets of gas can collect around the locomotive during filling.

To light the burner, hold a lighted match or cigarette lighter over the top of the chimney and **slowly** open the gas regulator by turning it anti-clockwise. The gas should ignite almost immediately with a pop as the flame travels down the chimney and into the boiler tube. The burner should be audible but not too loud.

The full range of adjustment (closed to fully open) is achieved within the **first full rotation** of the gas regulator knob any more is unnecessary.

**NOTE** as stated above, the gas regulator should be opened slowly until the burner ignites. If opened too quickly, particularly when the engine is cold or if the gas tank has just been filled, it is possible

that the flame may not travel back into the boiler flue but stay in the smokebox. If this should happen, the burner will sound quite different to normal and the blue flame will be visible in the smokebox if viewed down the chimney from a safe height. Should this happen, turn off the gas immediately or damage may result and then re-light it. If the problem persists, and it is not possible to ignite the burner correctly, then a dirty jet should be suspected and cleaned as detailed in the trouble shooting section.

For the first couple of minutes keep the burner on low. This is important, as until it warms up, the flame will be a little unstable and turning it up too much could cause it to go out. Also, with a completely full tank, liquid gas could be drawn off instead of vaporised gas, which can also extinguish the flame.

After a couple of minutes, the gas control valve can be opened more to speed up steam raising.

## **Running the chassis**

When full working pressure has been reached (about 40psi), the safety valve will start to blow off steam. Steam generation can be controlled by the gas valve. If the safety valve blows off frequently during running, then too much steam is being produced, which wastes water and gas. Turning down the burner will decrease the amount of steam made. Conversely, if steam pressure is not maintained during a run, then the burner should be turned up. The art of balancing steam generation to the operational requirement by the adjustment of the gas control valve will quickly be learned.

The gas tank has a duration of about 25 minutes, though this will vary a little depending on gas valve setting. The boiler should not be allowed to run dry, and the gas tank capacity is such that the gas should run out before the water. When the gas is fully used up, the steam pressure in the boiler will be seen to gradually drop until the loco comes to a halt. Should the water expire before the gas is fully used, the pressure will drop rapidly and the loco will stop. Check the pressure gauge – if this is zero turn off the gas. No damage will result if the gas is turned off immediately.

On a manually controlled locomotive, there are three main controls.

- 1) **The gas regulator**, which should be used to control steam

generation as described earlier.

2) **The reversing lever.** This is moved fully forward for running in a forward direction and fully back to run in the reverse direction. It should be parked in the centre (mid gear) when the locomotive is stationary for any length of time. When in mid gear position, the valve gear is effectively in neutral and the engine will not move under steam power.

3) **The steam regulator.** This is the main steam control valve and regulates the speed at which the engine will run and is moved anti-clockwise to open and clockwise to close.

Using the reversing lever, select the desired direction of travel then open the regulator a little. Initially, there will be a certain amount of water in the pipes and cylinders which will exhaust through the chimney and, after a few moments, the engine will move jerkily as this clears. Once the parts have warmed up, the engine will move off steadily and its speed can be controlled with the regulator. Subsequent starts will be quite smooth once the cylinders etc. have reached their normal operating temperature.

To reverse the locomotive, close the regulator to bring it to a halt, move the reversing lever over and open the regulator again.

The art of fine control will soon be learnt with a little practice.

## **STORAGE BETWEEN OPERATING SESSIONS**

At the end of an operating session, it is good practice to clean the locomotive carefully with a clean soft cloth, and to oil all bright metal parts.

- \* Do not leave fuel or water in the tank or boiler for long periods.
- \* Do not store in places where the temperature may drop below freezing as water may still be present in the pipe work.
- \* Ensure all controls are closed and the valve gear in mid gear.

Periodically, wash off all traces of dirt and old oil from the moving parts with paraffin (not thinners) and apply fresh oil. This will stop the build up of dirt and grit.

## Trouble Shooting

### Gas System

This system is designed for use with Butane or Iso-Butane gas. Mixed gasses, i.e. Butane with a proportion of Propane mixed in, are available, and may be used if straight Butane is unavailable. These come in a variety of mixes ranging from 90/10 to 60/40 with one of the most common being 70/30. The figures refer to the proportions of the mix i.e. 70/30 contains 70% butane and 30% propane. If using mixed gasses, always choose the one with the largest proportion of butane. The addition of propane slightly alters the gasses properties. This can make the burner a little more difficult to light when cold or after filling the gas tank. Always open the regulator very slowly when lighting, and only just sufficient for ignition to take place. Opening too much too soon may extinguish the flame until the burner reaches normal operating temperature.

The tiny jet in these units can become blocked by small particles of dirt making the burner difficult to light, burn weakly at normal operating temperatures\*, burn in the smokebox or fail completely. If any of these should happen, clean out the jet as follows.

(\* On very cold days, a burner may start off burning weakly due to the temperature of the gas but should increase to its normal level as the engine warms up. This is quite normal)

Carefully, disconnect the gas pipe from the jet block using a 2BA spanner.

**Note** when connecting or disconnecting the gas pipe and jet block, do not use excessive force. Always hold the end of the gas burner near the air holes to support it otherwise it is possible to cause damage by bending the body. Slacken the screw retaining the jet block and slide it out to the rear. Remove the jet from the jet block using a 4BA spanner. Wash out the jet in fast evaporating thinner (Cellulose or similar). Blow through the jet from the front, which should clear most blockages. Although the hole through the jet is tiny, if you hold it up to the light you should be able to see quite clearly if it is blocked or not. If in doubt, fit a new jet. A spare gas jet is included with the toolkit. Do not use wire to clean the jet as this can damage the precision hole and may upset the delicate balance of the gas system. Reassemble in the reverse order, putting a small amount of PTFE tape round the thread of the jet. Ensure all connections are tight. When re-positioning the jet block in the burner, ensure that it is pushed in as far as it will go.

The gas regulator has a removable spindle and sealing gland that will require oiling from time to time if operation becomes either stiff or 'springy', causing difficulty in obtaining fine control over the burner. The spindle-sealing gland is an 'O' ring and is housed inside the regulator body. To lubricate it, unscrew the spindle fully by turning the control knob until it reaches the stop (approx 3 to 4 turns) then run a drop of oil onto the spindle and spring under the knob. Screw the spindle in and out several times to work the oil into the seal. It may be necessary to repeat the operation a couple of times.

## **STEAM LEAKS**

The cylinders are fitted with 'O' rings in the glands sealing both piston and valve rods. These can be adjusted with a spanner if steam leaks develop. They should only be tightened just enough to stop the leak, as over tightening will affect the running of the model. Cylinder covers are fitted with gaskets and valve chests with 'O' rings. A little 'bubbling' of oil may sometimes occur around these and is quite normal, however, steam leaking past the gasket should be attended to. If 'nipping up' retaining screws does not stop a steam leak, a service kit is available which includes replacement gaskets and seals and full instructions for fitting.

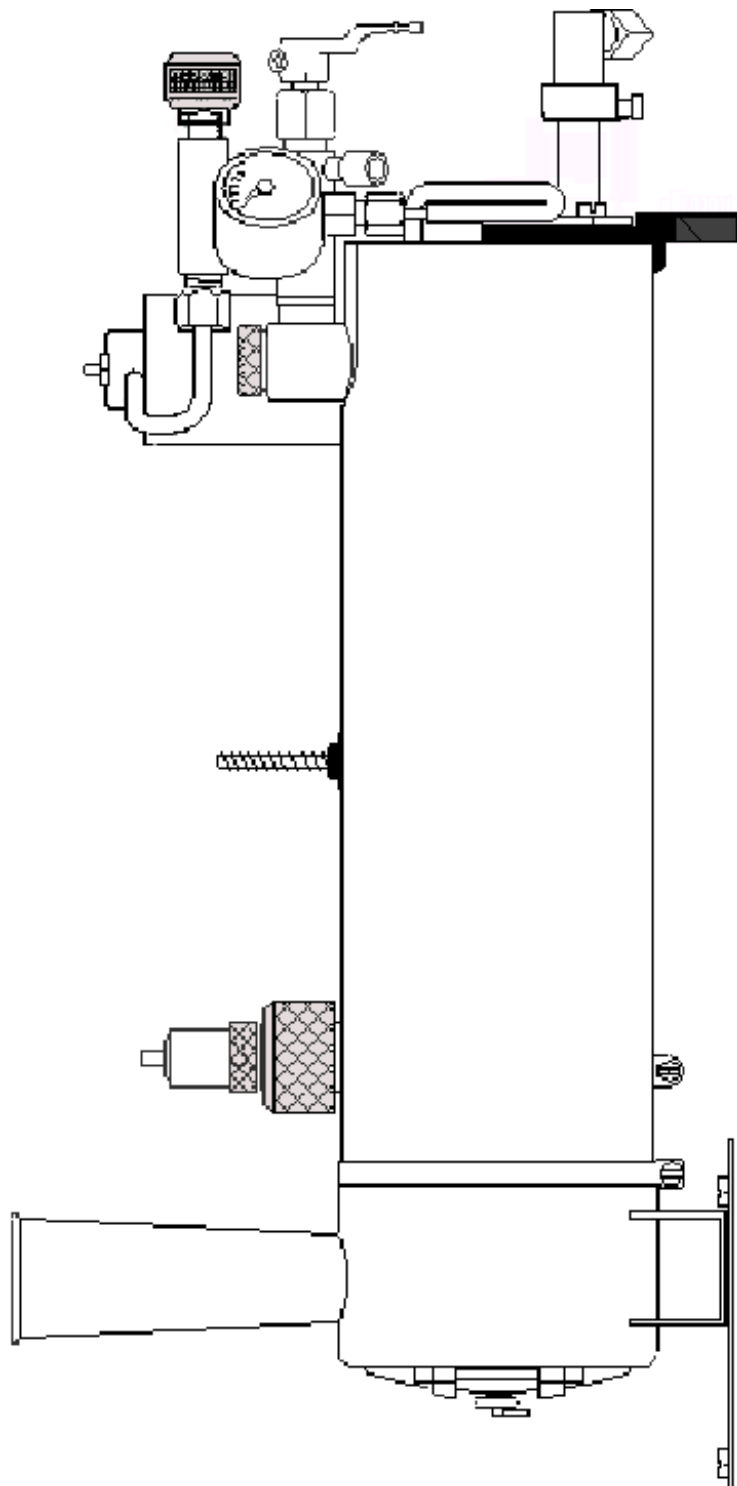

## HBK3 CHECKLIST - Billy Boiler Kit

- 1 2" x 6 3/8" (162mm x 51mm) single flue boiler.
- 1 Brass Boiler Wrapper with screws and nuts.
- 1 Safety valve assembly and 'O' ring.
- 1 Pressure gauge.
- 1 Manual steam regulator with handle & fibre washer
- 1 Boiler Blanking Plug.
- 1 Cast smokebox .  

---
- 1 Gas tank with gas regulator, gas pipe, gas filler valve and 2 6BA x 1/4" mounting screws & nuts fitted.  

---
- 1 Gas burner with gas jet, jet block & retaining screw.
- 1 Boiler mounting foot (long) with 3 screws and 2 washers fitted.
- 1 brass spacer plate.  

---
- 1 Stainless steel superheater with 'O' rings and union nuts.  

---
- 2 Boiler Bands with screws and nuts.  

---
- 1 Lubricator.  

---
- 1 Smokebox dart (*Continental type*) & M3 nut.
- 1 4BA Long Brass CSK screw, nut and washer.
- 1 M3 x 12 Brass CSK screw.
- 3 M3 Brass screws.
- 1 Allen Key for Steam Regulator Handle.  

---
- 1 Small bottle of steam oil.
- 1 60ml Syringe and tube.
- 1 pack of spare washers, 'O' rings and gas jet.  

---

**Parts Checked**

**Pressure Vessel Certificate Completed (page 17)**