



Modular Locomotive System

# HBK23 Fowler R/C Fittings Only Kit

## Instruction Manual

*Note: - this kit contains the parts to enable radio control equipment to be fitted to a 'Fowler' locomotive. No radio control equipment is included with this kit.*

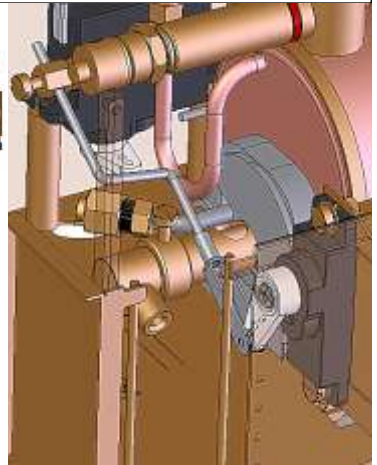
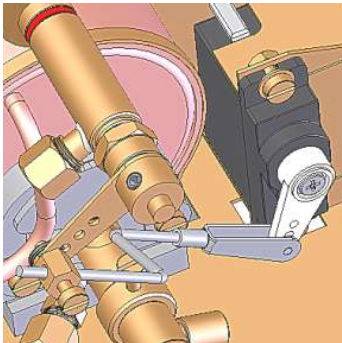

Roundhouse Engineering Co. Ltd.  
Units 6-9 Churchill Business Park. Churchill Road,  
Wheatley. Doncaster. DN1 2TF. England.  
Tel. 01302 328035  
Fax. 01302 761312  
Email. [support@roundhouse-eng.com](mailto:support@roundhouse-eng.com)

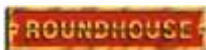

ONLINE [www.roundhouse-eng.com](http://www.roundhouse-eng.com)



# HBK23 Fowler R/C Fittings Kit

## Introduction

These instructions cover the fitting of radio control to the **'Fowler' 0-4-0** locomotive kit.

It contains all necessary parts to enable you to fit radio control equipment to a Fowler Locomotive.

Roundhouse locomotives can be fitted with several **different makes of radio equipment such as 'Futaba', 'Acoms' or 'Hitec' amongst others.** and all fixings and brackets are designed for this. If using radio equipment from another manufacturer, ensure that it is of similar specification to the 'Hitec' or 'Futaba' items mentioned in these instructions or problems could be encountered.

2.4Ghz digital proportional radio control equipment should be used as this gives fine control with the little, or no interference.

Before starting assembly, check contents against the list and read through the instructions fully, referring to diagrams where necessary, so that you identify all parts and understand where each is fitted.

## You will need to supply

A two-Channel Radio Control Set complete with :-

Transmitter.

Receiver.

Switch Harness.

2 x Micro Servos.

Battery Box.

2 x servo Extension Leads.

Suitable Batteries for both transmitter & receiver.

## List of Contents

- 2 Servo Mounting Posts.
- 6 M3 Brass Screws
- 4 M3 Brass Washers
- 2 Brass Nuts
- 2 Push rod connectors with screws and starlock washers
- 1 Short Steam Regulator (R/C type), complete with Regulator Arm with 1 grub screw and fibre 'O' washer.
- 1 Regulator control rod with Quicklink and lock Nut Approx 9cm long including Quicklink.
- 1 Reversing control rod with Quicklink and lock nut approx 19cm long including Quicklink.
- 4 Plastic cable ties.
- 4 Double sided sticky pads



You will need to supply  
A two-channel 2.4Ghz Radio Control set, complete with transmitter, receiver, switch harness and two micro **servo's**. **Standard or mini** servos will not fit correctly. Equipment with more channels can be used but only two channels are needed for this locomotive.

## Construction

### Remove Roof and Gas Tank.

First of all we need clear access to the cab in order to fit the servos and change the steam regulator.

First, using a 2BA spanner, loosen the gas pipe where it connects to the gas jet holder. Then remove the 4 screws that hold the roof assembly to the support posts.

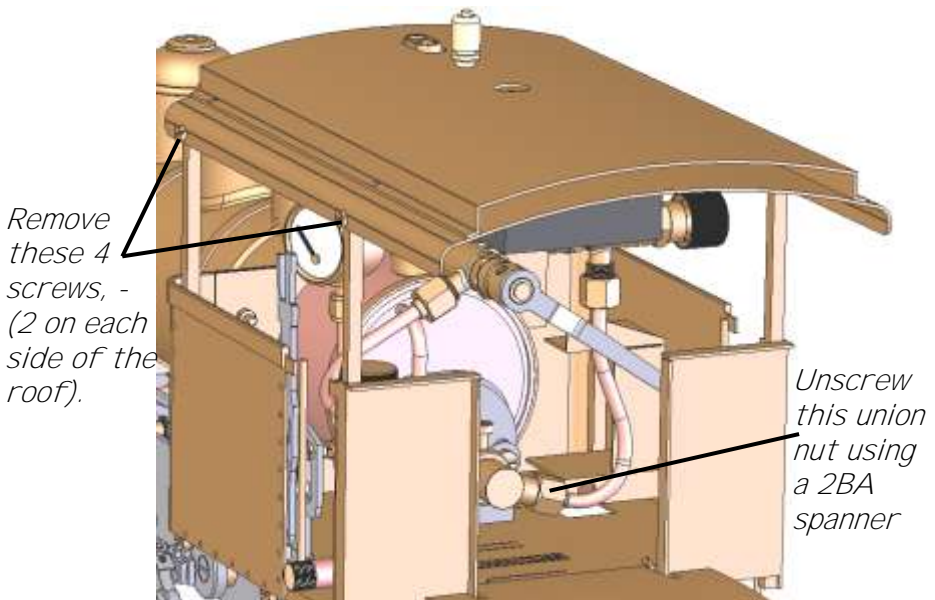

The complete roof with the gas tank and gas pipe can now be removed as one unit.

We now need to remove the manual reversing lever, located in the Left-Hand side of the cab. The link rod to the lifting arm should be disconnect from the reversing lever. Then, from underneath the left hand side of the cab, remove the 2 screws that hold the reversing lever to the cab floor.

*Remove these 2 screws and then lift out the Reversing Lever.*

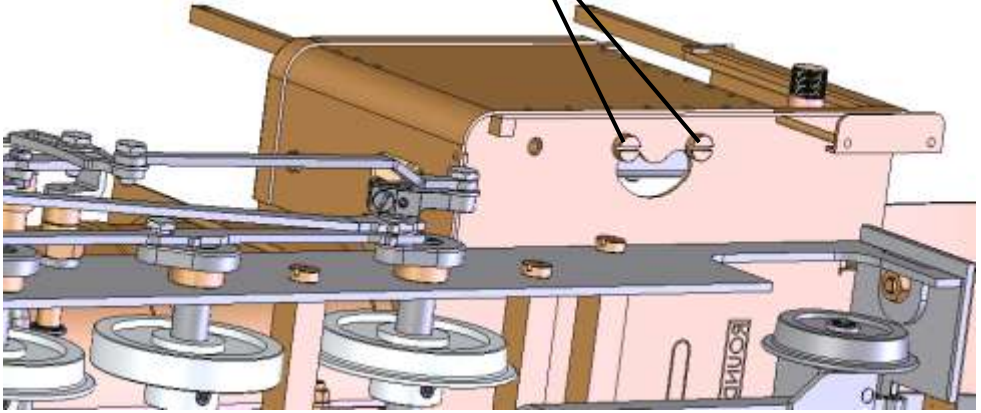

We can now change the Steam Regulator. First, using a 2BA spanner, loosen the union nut on the lubricator pipe where it connects to the Steam Regulator. The lubricator pipe can then be bent slightly away to allow the steam regulator to be unscrewed using a pair of pliers, preferably round-nosed.

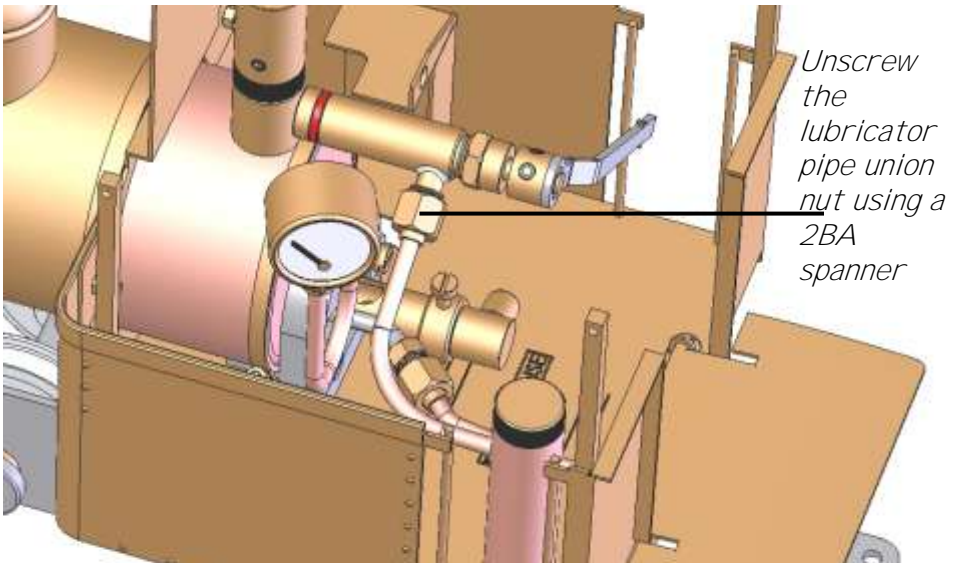

*Unscrew the lubricator pipe union nut using a 2BA spanner*

A replacement radio control type steam regulator is supplied with this kit. Although externally it looks the same as the manual type supplied with the boiler kit, internally it is quite different. It is designed to operate with a servo where a small amount of movement must give full control from closed to fully open. It also relies on an 'O' ring to ensure that it closes fully with the minimum of force.

Although the standard needle valve type steam regulator supplied with the boiler kit can be used with radio control, its operation, particularly in closing fully, is not always reliable.

First, fit the push rod connector to the fourth hole of the new regulator arm. Push the spigot through the hole from the front and push the Starlock washer over the spigot to lock it on. Fit the screw in the end of the connector loosely.

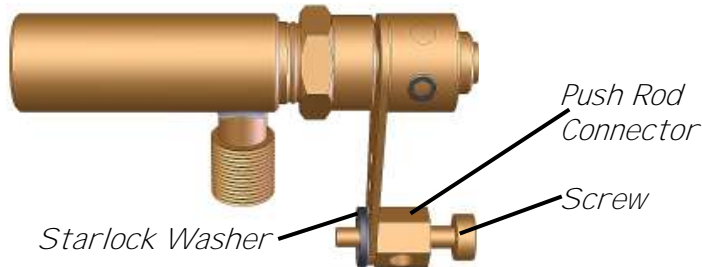

Fitting of the Radio Control type regulator to the boiler is the same as for the manual type described in the boiler kit instructions. Use the new fibre washer. The boiler kit instructions are available on our website, if required.

Fit the Radio Controlled type steam regulator so that the outlet finishes in the same position as the manual type regulator that you removed. Bend the lubricator pipe back into position and connect to the Steam Regulator using a 2BA spanner.

## Reversing Servo

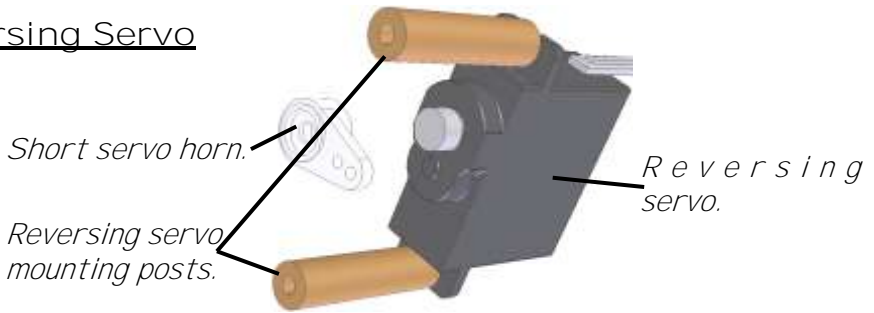

The reversing servo that operates the Walschaerts valve gear can now be fitted.

The servo mounts on to the left hand side of the footplate with the lead to the rear, using the two brass posts. Fit the brass servo posts to the servo first, using two M3 brass screws and the two large brass washers. Do not fit the short servo horn yet.

Fit the servo and posts to the cab floor with two M3 brass screws using the holes in the cab floor as shown below. The lead should be fastened to the bottom of the rear servo mounting post with a plastic cable tie, and then passed down through the hole in the cab floor.

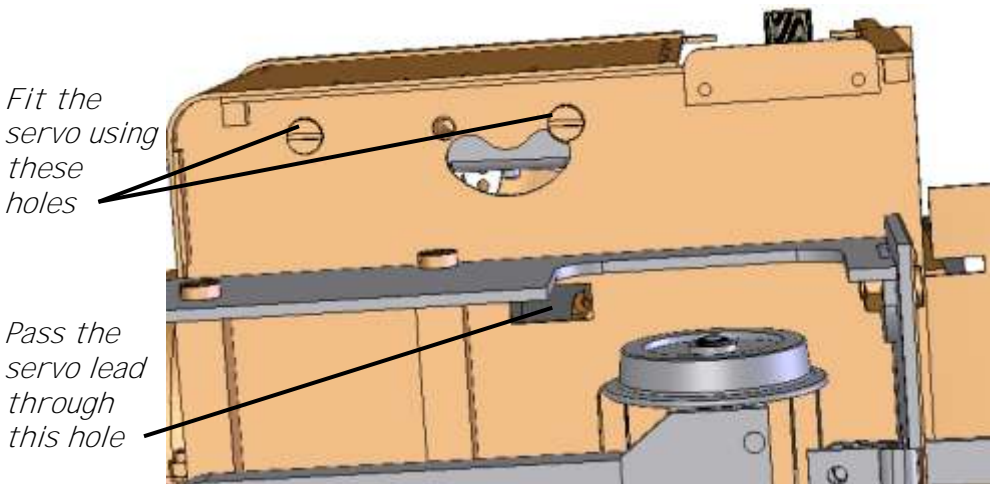

## Regulator Servo

Fit the regulator servo to the bracket on the right hand side of the foot plate (which you fitted during the body construction).

The servo is passed through the rectangular hole in the bracket with the lead to the top. The lead can then be passed down the front of the servo and through the rectangular hole in the footplate at the bottom of the servo. Fasten the servo in place with two M3 screws, nuts and washers through the top and bottom mounting flanges.

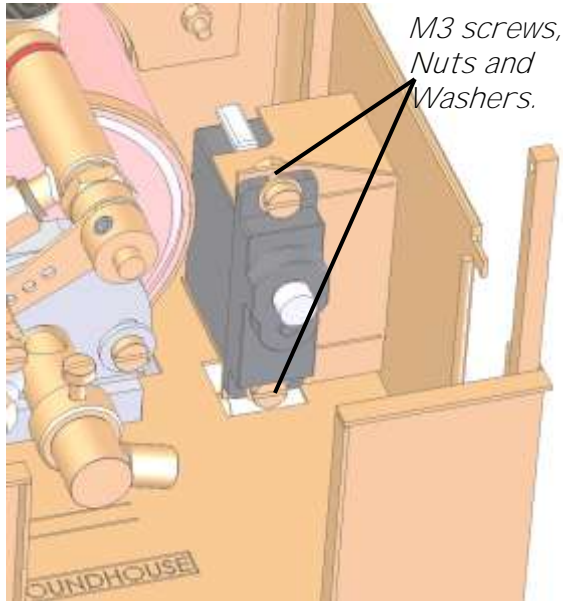

Do not fit the horn or linkage at this time.

## Switch

Fit the switch to the Front Panel of the Tender as shown in the drawings below. We fit the switch so that the ON position is to the middle of the tender.

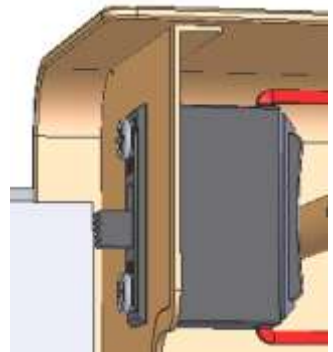
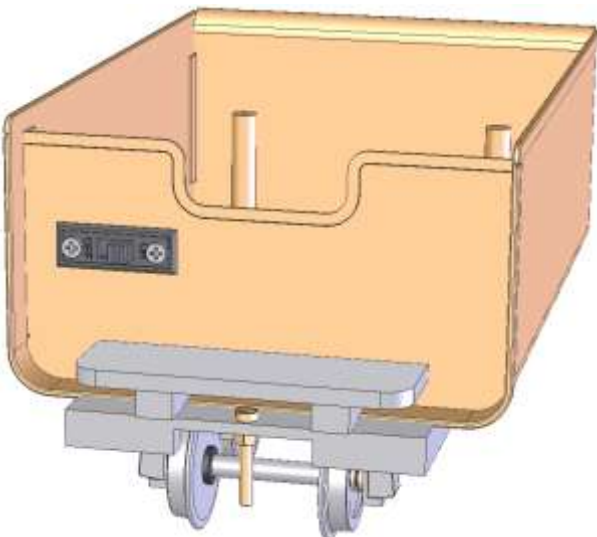

When connecting the Switch, you will need to refer to the instructions supplied with your Radio Control Set.

One of the switch leads will plug into the receiver, and other lead will go to the battery holder. Switch harnesses from different manufacturers vary in length and the type of plug and socket used to connect their battery holder. The Receiver and Battery Holder are simply placed in the tender.

In order to set and adjust the linkages, the radio control equipment must be connected up and batteries fitted.

The leads from the servos are routed under the cab floor and held in place by two clips that are etched into the cab floor. Gently push these clips down slightly. Carefully turn the locomotive upside down and remove the rear Pony Truck.

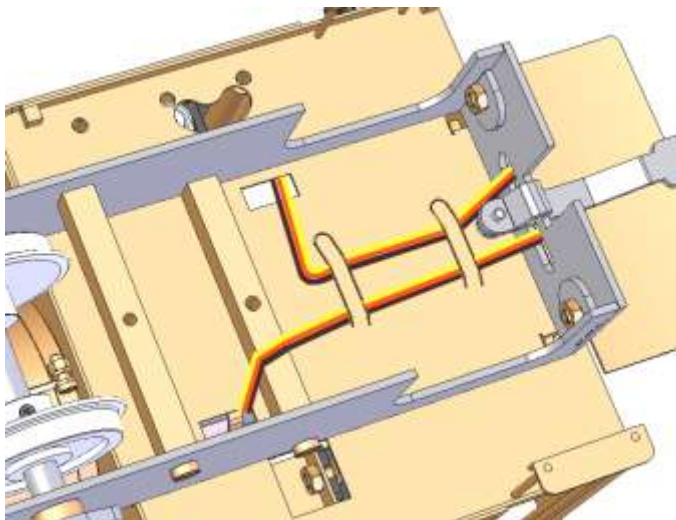
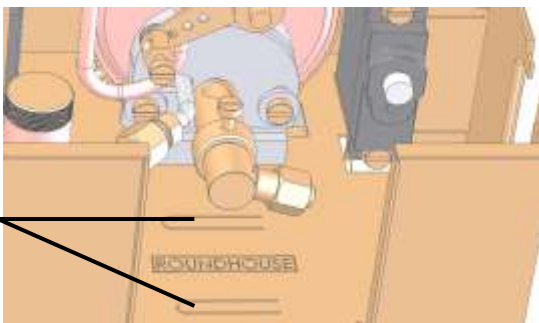

Route the two servo leads out through the slot in the rear buffer beam as shown in the drawing opposite. Gently push the clips back towards the cab floor to hold the servo leads in place. Take care not to damage the leads.

The Servo Leads are not long enough to reach into the tender and so we need Servo Extension Leads. Connect these to the servo leads and then feed them under the tender step and into the tender. Plug the lead from the regulator servo into channel 2 on the receiver and the lead from the reversing servo into channel 1. Note: - these Channels can vary from set to set.

All loose wires, except the long battery and aerial wires, can be tidied up using the cable ties supplied. Ensure that none are in contact with hot pipes or fittings and that they are out of the way of any moving parts.

Now that the main items are installed, we can fit and adjust the linkages. First however, the spring which self-centres the left hand (regulator) control arm on the transmitter needs removing. The right hand control (reverser) can be left sprung loaded to centre as this gives a convenient mid-gear position. Refer to the manufacturers instructions regarding the removal of this spring as details vary on different makes of radio control equipment.

When the transmitter modification is complete, fit the required batteries into the transmitter and the battery holder in the tender.

Switch on both transmitter and receiver.

Moving the right hand control lever on the Transmitter should now cause the reversing servo to operate and moving the left hand lever should cause the regulator servo to operate. If this is not the case, check all connections and batteries.

Set the reversing servo up first, as follows.

Prepare a servo horn so that it has a single arm with a

connection hole approximately 8mm from the centre. If none of the arms supplied with your Radio Control set have a suitably positioned hole, you will have to drill one using a 1/16" or 1.6mm drill. The positioning of this hole is quite critical as it will affect the travel of the radius rod in the expansion link, but as different makes and types of servo have slightly different angles of movement, it is not possible to give an exact measurement - some trial and error is required.

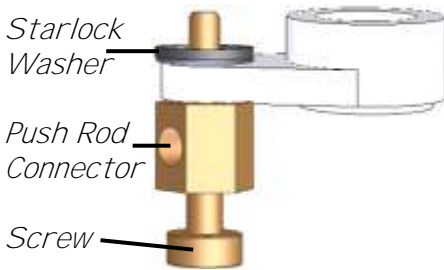

Fit a push rod connector as shown. Push the spigot through the hole from the front and push the Starlock washer over the spigot to lock it on. Fit the screw in the end of the connector loosely. Trim the plastic servo arm to length.

Ensure that the control lever on the transmitter is in the centre and that the trimmer (small black lever below the main lever) is also in the centre then push the short servo arm up onto the splined servo spindle pointing in towards the boiler at 90 degrees and fix in place with its retaining screw. The shaped cut-out in the footplate below the servo will allow screwdriver access to the horn and push rod connector screws. This has now set the servo horn for mid gear and moving the control lever either way will move the horn accordingly. Set up the transmitter, using the servo reversing switch if necessary, so that moving the lever to the left engages forward gear (moves horn forwards) and to the right engages reverse (moves servo horn to the rear).

If the reversing control rod already fitted is long enough then remove it from the lifting arm and use it here. If it is

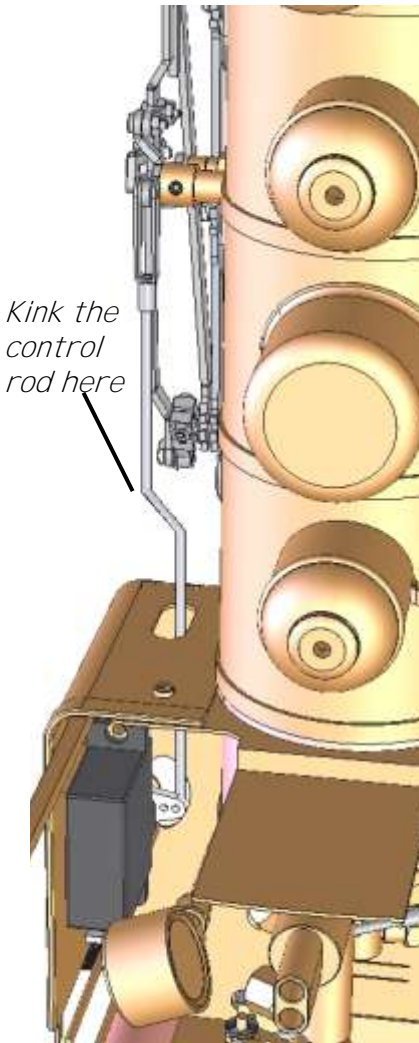

too short then discard it and use the longer of the two Quicklink rods provided in this kit. The rod **will need to be 'kinked' inwards** towards the chassis so that it can fit through the hole in the front of the Left Hand Cab.

Connect the Quicklink connector into the hole in the lifting arm by springing open the end of the Quicklink and passing the pin through the hole in the top of the lifting arm.

Now, check for movement to full gear in both directions and make fine adjustments to the linkage by moving the rod in the push rod connector until the radius rod moves an equal amount both up and down the expansion slot.

Note that the radius rod should not travel the full length of the expansion link, but should stop a small distance from either end.

On some transmitters there is an extra refinement to aid us in this setting in the form of three extra 'trimmers'. The left hand one labelled 'Throttle Quick Trim' can be ignored, as this now has no function. The other two, labelled 'CHI ATV CH2' control the amount of rotation of the two servo spindles and 'CH 1' can therefore be used to adjust the maximum raising and lifting of the radius rod.

Set the left hand control lever on the transmitter to the bottom and ensure that the trimmer at the side of it is at the top. This will park the servo in its normally closed position.

Take a single arm plastic servo horn - this should be included with your Radio Control set. The number of holes in the servo can vary. Usually there are 3 or 4 holes. Fit the horn to the regulator servo so that it is pointing to between 8 and 9 o'clock on a clock face and fix it in place with the small screw provided. When the left hand control lever is moved upwards, the servo horn should rotate anticlockwise. If the servo horn rotates clockwise, use the servo reverse switch located on the transmitter, then reposition the servo horn as detailed above.



Gently turn the regulator arm clockwise with your fingers to close it, but do not force it. When closed, the regulator arm should be roughly parallel to the servo horn. If not, use the Allen key to loosen the grub screw and move the regulator arm to the correct position.

We now need to connect the servo horn to the regulator arm. Take the short Quicklink rod. This will need to be **'kinked' to fit, similar to how the reversing control rod was bent.**



*Short Quicklink Rod,  
bent to shape.*

First, pass the plain end of the rod through the push rod connector on the regulator arm, and then clip the Quicklink into either the 2nd or 3rd hole on the servo horn. The Quicklink is best fitted by slightly spreading apart the two sides with a screwdriver as it is passed over the plastic servo horn. Refer to the drawings below that show several different angles of how the rod connects.

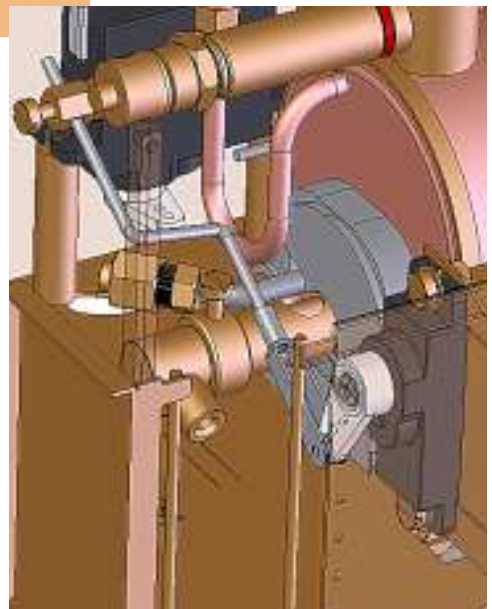
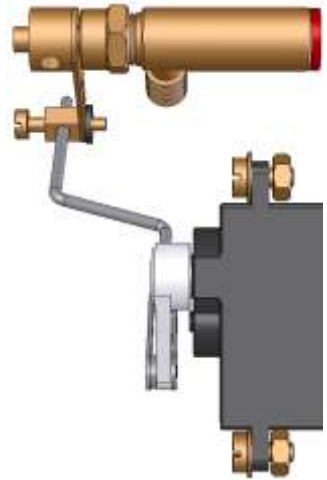
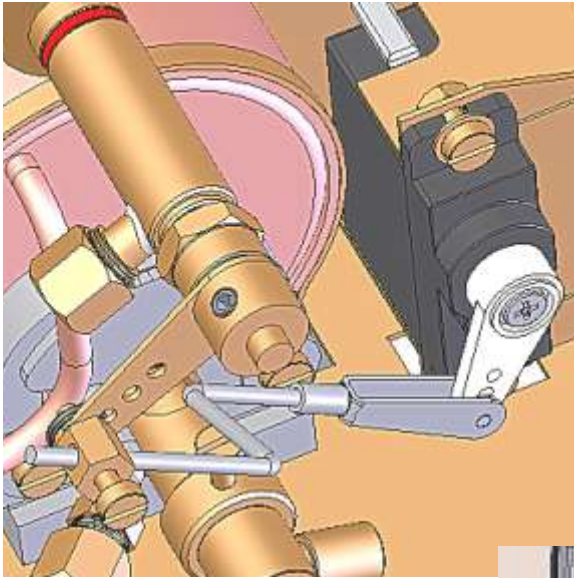

The Roof and Gas Tank can now be refitted. Take care to ensure that all fittings, especially the gas ones , are fully tightened.

Setting and adjustment of the regulator is best done with the locomotive in steam and with the chassis supported on two wooden blocks under the chassis to raise the wheels off the bench. Ensure that the regulator is closed when raising steam.

When full working pressure is raised, switch on both transmitter and receiver and move the locomotive into gear with the right hand lever on the transmitter. Open the regulator by slowly moving the left hand lever upwards and find the position at which the engine starts to run. Move the arm backwards and forwards a few times to establish the position at which it closes and leave it there.

If the regulator does not open or fails to close fully, slacken the grub screw holding the regulator arm in place, remove the arm and turn the spindle manually (careful as it's hot!) to find the point at which it just closes. Move the control lever on the transmitter to the bottom and replace the regulator arm. Proceed as before to find its closing position and leave it there. Carefully slacken the grub screw and move the control lever to the bottom without moving the spindle. Nip up the grub screw.

You can make fine adjustments to the linkage now until the regulator closes fully with the control lever at the bottom. Because of the 'O' ring used in the Radio Control type regulator, you should aim for the wheels to start moving when you have moved the control lever on the transmitter about half way up. This is because the 'O' ring will compress slightly into its seat when fully closed. You may need to adjust the position of the arm on its spindle.

When satisfied that all is adjusted correctly, tighten all screws, switch off the gas burner and Radio Control equipment and disconnect battery clip. Trim off any excess servo horn. The trimmer at the side of the control arm can be used in the future to compensate for wear and compression of the 'O' ring. As time passes, you may find that the regulator does not fully close when the control lever is at the bottom. As this happens, the trimmer can be moved down a little at a time to compensate.

We have provided some double sided sticky pads that can be used to secure the Receiver to the tender.

This concludes the fitting and adjustment of the radio control equipment.

