



# Modular Locomotive System

Instruction Manual

For

# HBK2

Lady Anne 0-6-0 Walschaerts Chassis

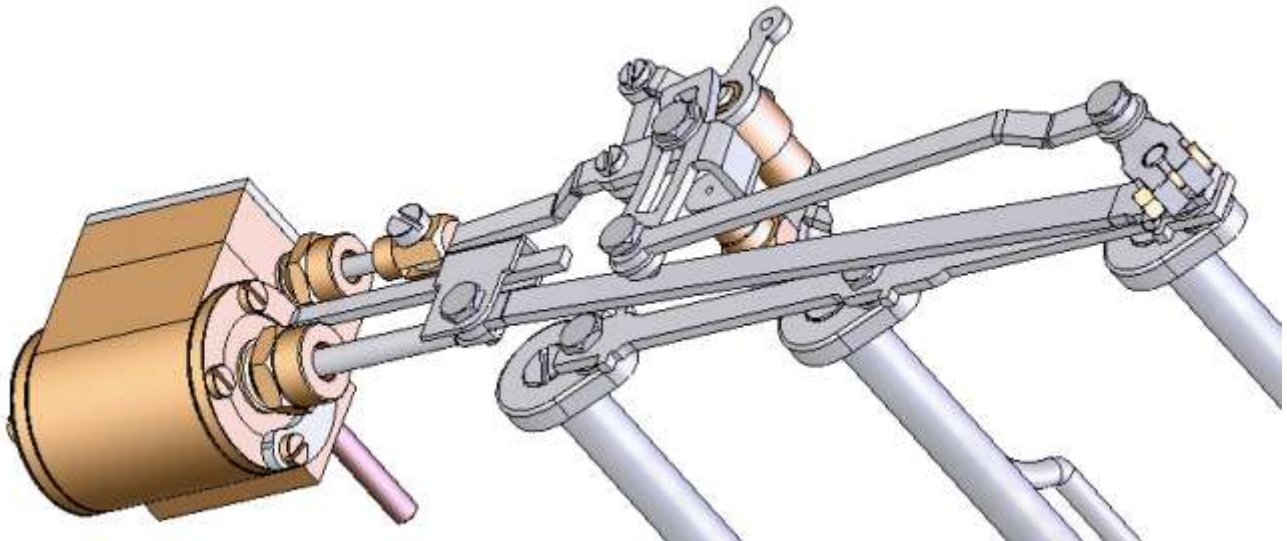

**Roundhouse Engineering Co. Ltd.**

Unit 6-9 Churchill Business Park

Churchill Road. Wheatley

Doncaster. DN1 2TF. England

Tel. 01302 328035 Fax. 01302 761312

Email: [support@roundhouse-eng.com](mailto:support@roundhouse-eng.com)

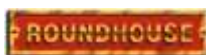

ONLINE

[www.roundhouse-eng.com](http://www.roundhouse-eng.com)



# HBK2 Lady Anne 0-6-0 Walschaerts Valve-Gear Chassis

## Introduction

These instructions cover the construction of a 0-6-0 chassis with Walschaerts type valve-gear. The valve gear is of a simplified design, which does not make use of a combination lever. No machining is necessary, though certain parts may require the use of hand tools to obtain a good fit and, a small number of holes require drilling during the construction of the valve-gear. In the following pages, we will take you through the construction step by step with the aid of both written instructions and diagrams, just as we build the locomotives in our works. We have made the instructions as clear and concise as possible and have tried to show where and what problems are likely to be encountered and how to overcome them. This is not a 'build it in one evening' kit, however, anyone with a little patience and care can build a working steam locomotive to be proud of using the minimum of hand tools.

Before starting to actually assemble the chassis, check the contents against the list and read through these instructions fully so that you identify all parts and understand where each is fitted. Refer to diagrams at all times as these will make it clear which way round certain parts go and what holes are used.

From long experience, we have found that with this type of working model, it does not pay to work to 'close fits' in certain areas when assembling. Pay attention to any clearances and slotted holes etc. otherwise you may find that the first time you steam it up it will not run. The reason for this is expansion. A lot of heat is used to generate the steam and a lot of this is passed through the loco causing all parts to expand. As several different materials are used and some items get hotter than others, expansion is not uniform throughout. What seems perfectly free running when cold can lock up solid when hot unless allowances have been made.

The more adventurous builders may wish to use this chassis kit as a basis for their own model and, there are many ways in which it can be modified to suit a different design. We do however suggest that, unless you know exactly what you are doing, you should not alter in any way the relationship between cylinders, valve-gear and drive axle. The geometry of the valve-gear is quite precise and any alteration could have a bad effect on the smooth running of the finished engine.

### Tools Required

The following tools will be required during construction: -

Small and medium sized screwdrivers.

Small (Swiss) files (needle files).

Drill with either a 1.6mm *or* 1/16" drill bit.

Pair of pliers.

Small clamp (tool makers clamp or similar)

## Construction of the main-frames

### Diagram 1

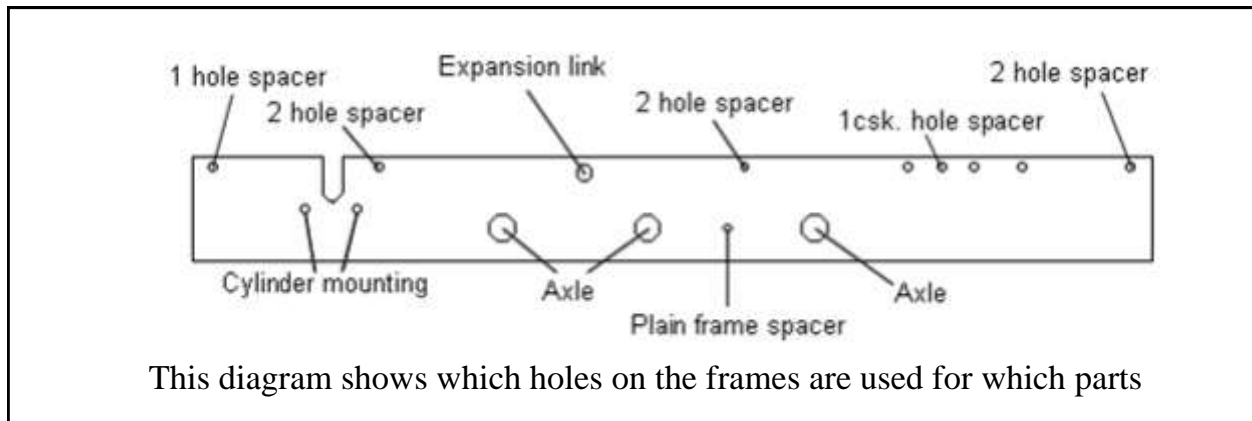

Using the M3 brass screws, fit the six frame spacers to the inside face of one of the mainframes. The four with tapped holes and one with the countersunk plain hole are the top spacers and should be positioned as in diagram 1, with the tapped holes sitting vertically and the countersink to the bottom. The plain spacer is the centre one to the bottom of the frame. Use the two M3 CSK screws to fix the rear 2 hole spacer to the frames. The holes in the frames are Countersunk (CSK) to take these screws. This will make fitting the Body Kit (HBK6) easier, should it be used.

The main bosses of the axle bushes should be to the outside. Offer up the other side, with its axle bush bosses pointing outwards and screw it to the frame spacers with more M3 brass screws.

This is a convenient point at which to paint the frames and buffer beams.

This is best done using acrylic paint which is readily available in spray cans. Cellulose or enamel paints are also available and can be used if preferred. The metal should be thoroughly cleaned to remove the anti rust oil with which they are coated during manufacture before being primed and painted with colour.

The buffer beams can now be fitted using the M3 brass screws and nuts. The centre buffers can be fitted to the buffer beams using a M3 brass screw from underneath. The rounded edges of the buffer beams are to the bottom, and the tab that is bent back should be to the inside.

The wheels and axles can now be fitted after first cleaning any paint out of the axle bushes and checking for free running by pushing an axle only, through each pair of bushes.

Start with the rear wheels first and push an axle through one side bush, slip two wheels on and push it through the other bush. Ensure that the wheels are fitted the correct way round with the fixing bosses with their grub screws to the inside. Now fit an outside crank on each end, using the two that have the plain crank pins ready fitted. The crank pins should of course be pointing out. The outside cranks have square holes in their centre to ensure that the 'quartering' is correct. One side of the centre hole is also countersunk, which should be to the outside. The fixing screw will fit into this countersink and may stand slightly proud of the outside crank.

Now convention says that the right hand side should lead. All this means is that when running forward, the right hand crank is 90 degrees or quarter of a revolution in front of the left, hence the term 'quartering'. We always go along with this, though it would make no difference at all to the running if it were the other way round. Ensure that the cranks are tightened on well using the 4BA steel CSK screws. The cranks are a tight fit on the ends of the

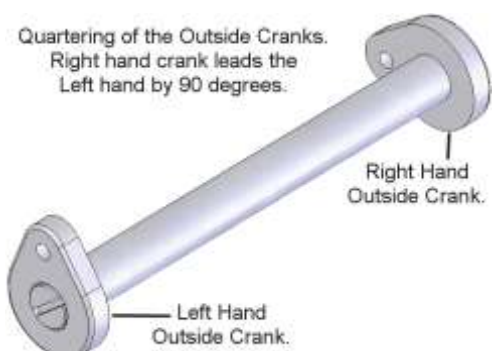

axles, and will need to be pressed on with a 'G' clamp before actually fitting the screws. Check the end float in the axle by sliding it from one side to the other and, if this movement is excessive, fit one of the 1/4" bore steel washers onto the axle between the outside crank and the axle bush on one side only. As a general rule, with the axle held firmly over to one side, if a washer can be easily slipped into the gap between outside crank and axle bush and still leave a little space for side movement, then it should be fitted.

Repeat for the front axle using outside cranks without crank pins.

Repeat for the centre axle but use the flangeless wheels and outside cranks without crank pins.

The driving wheels are moveable on their axles and are locked in place by a small grub screw. They should be adjusted so that the gauge supplied will just slip between their inner faces. Ensure that the wheels are evenly spaced relative to each side frame. Do not over tighten the grub-screws. Note that the wheel gauge can be used for either 32mm gauge (SM32) or 45mm gauge ('G' scale) depending on which end is used.

Make sure that all three axles rotate freely then fit the coupling rods.

Note that the distance between front and centre axle and rear and centre axle are not the same so the coupling rods will only fit one way.

To begin with, forget the centre axle and treat the chassis as on 0-4-0 as this makes it easier to find any tight spots in the motion. Push a 5BA steel washer over one of the rear crank pins then push the coupling rod on. Connect the front end to its outside crank using a short crank pin and another steel washer. Repeat for the other side.

Slowly rotate the wheels and feel for any tight spots. If it sticks at all, look which side has its outside cranks at or near front or rear dead centre (that is pointing to the front or rear of the chassis) and on that side, slightly elongate the front coupling rod hole with a small round file. Remove only a very small amount at a time and keep trying it until the wheels rotate freely without any tight spots. Now, fit a short crank pin and washer to one side only through the centre hole in the coupling rod and into it's outside crank. As before, rotate the wheels and check for any tight spots. If there are, then this side centre hole will require slightly elongating as before. When this is running freely, repeat for the centre hole on the other side. In this way, you should end up with all six cranks connected and the wheels running freely. Don't forget that a 5BA steel washer should be between the rod and the outside crank on all six cranks.

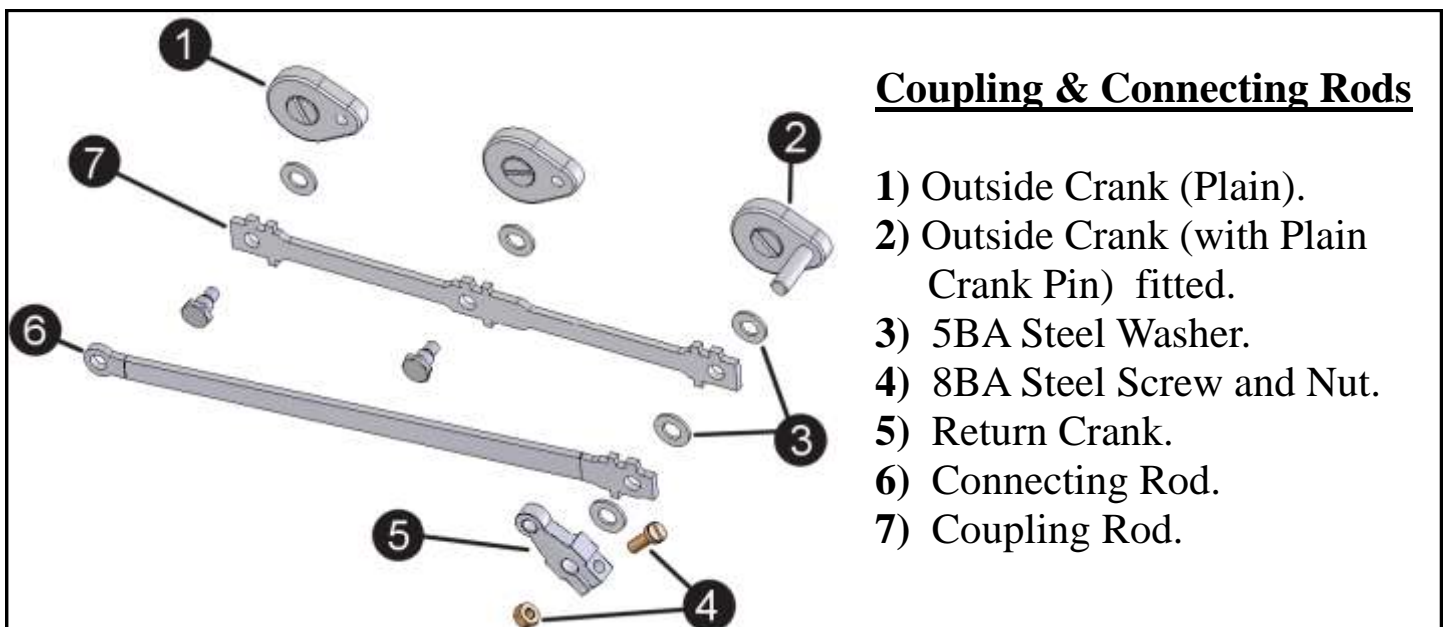

We can now move on to the cylinders.

Using two socket cap mounting screws and washers, fix one cylinder block to the chassis through the 2 outer holes of the 4 on the frame. Make sure that the washer fits between the head of the socket screw and the frame. The copper exhaust pipe should be bent forwards and slightly up out of the way. The exhaust pipes are screwed into the cylinder blocks, so take care when bending them not to snap the thread where it enters the cylinder block. Don't worry about its final position at this stage. Check that the cylinder blocks are level with the tops of the frames, and tighten up the socket screws with the Allen Key provided.

Place the slide valve onto the top of the cylinder block, so that it is covering the three holes (ports) in the centre. Lay one of the black valve chest 'O' rings over the slide valve, so that the slide valve is sat in the middle of the 'O' ring.

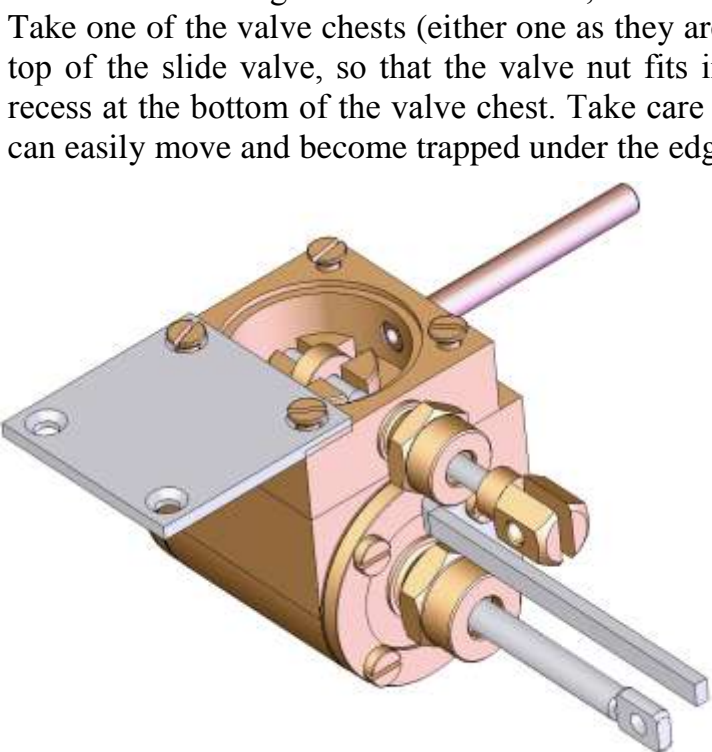

Take one of the valve chests (either one as they are both the same), and carefully place this over the top of the slide valve, so that the valve nut fits into the slide valve, and the 'O' ring fits into the recess at the bottom of the valve chest. Take care here that the 'O' ring does fit into the recess as it can easily move and become trapped under the edge of the valve chest. Also check that the valve nut has the round side facing uppermost, and that the flat side is located in the slide valve slot.

Using just two of the brass countersunk screws, half fit the valve chest cover so that it is offset to the outside, as shown in the opposite diagram. This allows you to see into the valve chest to adjust the position of the slide valve later on, when setting the timing. Do not fit the top valve chest 'O' ring at this stage. The steam inlet pipe, which is the upper and shorter copper pipe, should be left straight and pointing into the centre of the chassis.

If you intend using the **ROUNDHOUSE** HBK4 gas fired boiler kit and have already purchased it, now is a good time to fit the stainless steel superheater, which is included with it. If not, you can continue construction of the chassis and fit it at a later stage, but you will need to fit it before an air or steam test can be carried out. If you are fitting your own boiler to this chassis, the superheater is available from **ROUNDHOUSE** as a separate part if required.

The superheater has a 'T' connector silver soldered to one end which connects the two cylinders. Slide one of the 2BA hexagon union nuts onto the steam inlet pipe followed by an 'O' ring then, slide one end of the 'T' on and loosely screw the union nut onto it with the 'O' ring inside. The superheater should be pointing upwards for now. Put a union nut and 'O' ring onto the inlet pipe of the second cylinder and fit this cylinder as before to the chassis, ensuring that the inlet pipe fits into the open end of the 'T'. Loosely screw the second union nut onto the 'T' then position it centrally between the frames and tighten up both union nuts just sufficient to squeeze the 'O' rings a little. Don't over-tighten or you will crush and damage the rubber 'O' rings.

Extend both piston rods and check that they are parallel to the top or bottom edge of the chassis, or more simply, that they are pointing straight at the centre of the rear axle. If not, slacken off the two cylinder-mounting socket screws which you have just fitted through the frames, move the cylinder round a little until it is in line and re-tighten the screws.

Now the connecting rods can be fitted. The smaller, rounded end of the connecting rod fits to the piston rod, and the larger squared end fits over the rear crank pin. The two lugs on the squared end of the rod should be to the top, and the single lug to the bottom. The rods are cranked, as the piston rod is further out from the chassis than the outside crank. Fit a 5BA steel washer over the rear crank pin then slide the connecting rod 'big end' on. Push the crosshead screw through the stainless steel crosshead then through the connecting rod 'little end' and finally screw it into the end of the piston rod.

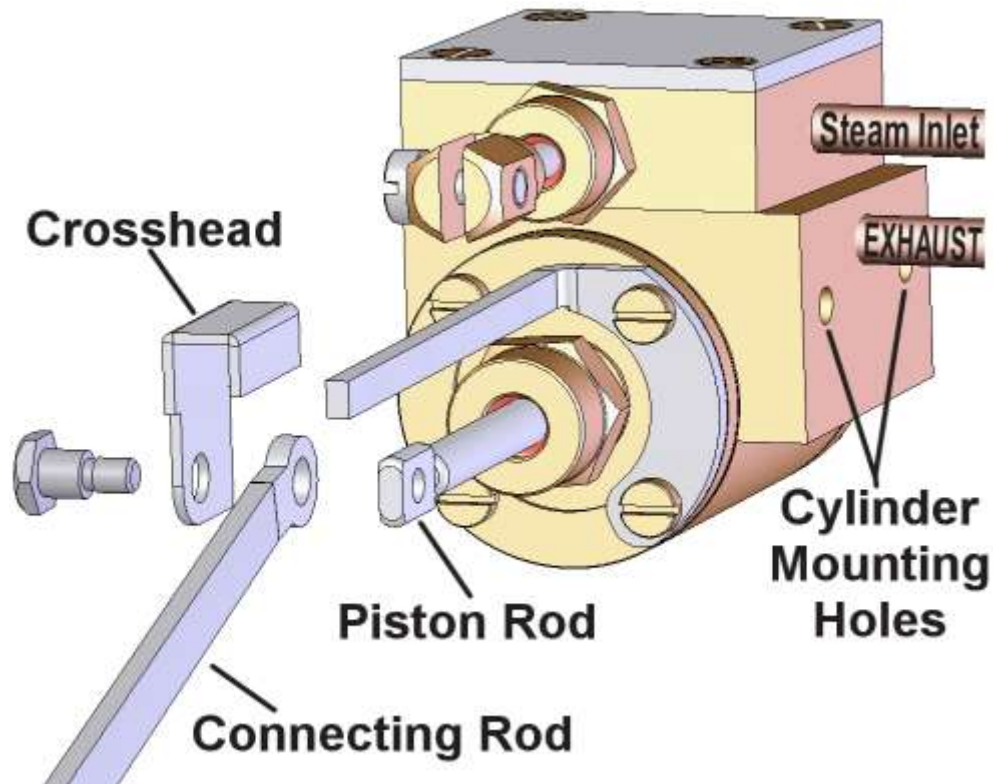

Repeat for the other side then rotate the wheels to check that it all operates smoothly. You will now feel the resistance of the pistons sliding up and down the cylinders, though there should be no tight spots.

We are now ready to move onto the valve gear.

### Construction of the Walschaerts type valve-gear

Refer to the diagram on the next page which shows an exploded view of the left-hand valve gear.

Fit the return cranks first, as these will then retain the coupling and connecting rods, not forgetting yet another 5BA steel washer between the return cranks and the connecting rods. The positioning of these is critical to the correct running of the engine and when the valve-gear is all assembled and tested, they will be pinned in place to prevent any movement. For the moment however, just clamp them in position using the steel screws and nuts provided. Refer to the diagram and note that the return crank always leads the crank pin in forward rotation.

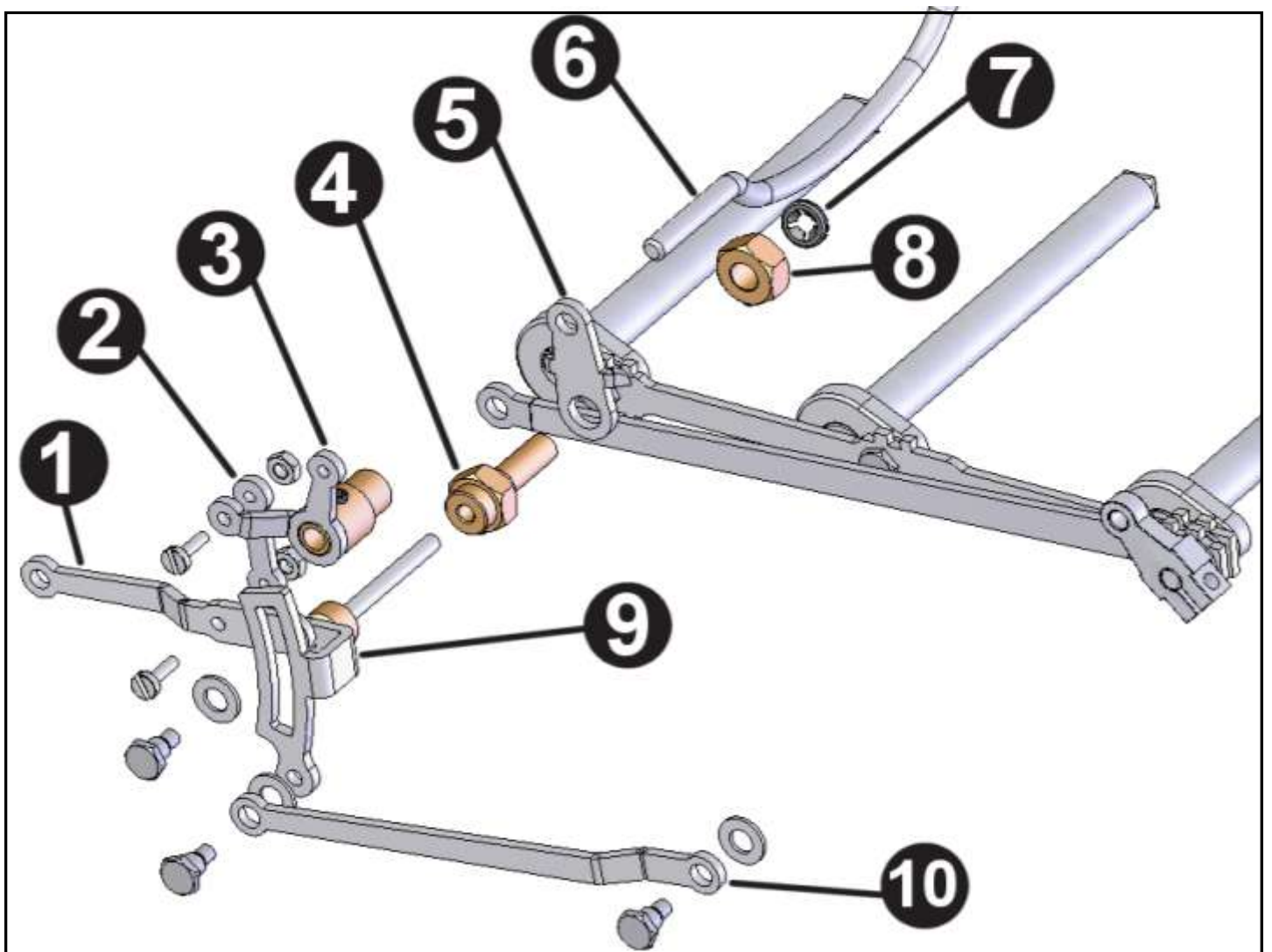

### Assembly of Walschaerts type valve-gear

- 1). Radius Rod. 2). Lifting Link. 3). Lifting Arm. 4). Expansion Link Bush.  
 5). Weigh Shaft Bracket (Penguin). 6). Weigh Shaft. 7). Starlock Washer.  
 8). 2BA Nut. 9). Expansion Link. 10). Eccentric Rod.

The weigh shaft can now be assembled. Take one weigh shaft bracket or 'Penguin' bracket as they are commonly known at **ROUNDHOUSE** (use your imagination here!) and push the threaded part of an expansion link bush through the larger (bottom) hole. Note that the smaller top hole is offset and when bolted to the frame, will be slightly in front of the expansion link pivot point. The two small 'wings' sticking out from the sides of the 'Penguin' brackets should be bent backwards a little with a pair of pliers. These will locate on the top face of the chassis to keep the bracket in position. Remove the expansion link from the bush and unscrew the nut. Push the expansion link bush through the hole in the chassis and fit the brass nut on the inside.

When tightened up, the 'Penguin' bracket is held tight against the outside of the frame with its 'wings' resting on the top edge and the top hole leaning slightly forward. Take care not to over tighten the nut as the bush may break.

Before fitting the weigh shaft, it should be checked to see that the two straight sections at each end are in line. To do this, simply hold a straight edge (ruler etc.) along its length. Any slight adjustment needed can be done by a little gentle bending of the curved section until both ends are in line. Now slide one end of the weigh shaft through the top hole and repeat the procedure with the other side.

The pivot pins on the expansion links can now be pushed through the bushes. Note that these are handed and, with the tapped hole to the bottom, the U shaped extension which connects the expansion link to its pivot pin should be to the rear. Starlock washers are pushed onto the ends of the pivot pins between the frames to hold them in place, but should not be pushed on so far that they prevent free rotation.

The eccentric rods can now be fitted to connect the return cranks and the expansion links. These rods are slightly tapered and the thicker end has a 'joggle'. They are attached by the shouldered crank pins with a washer

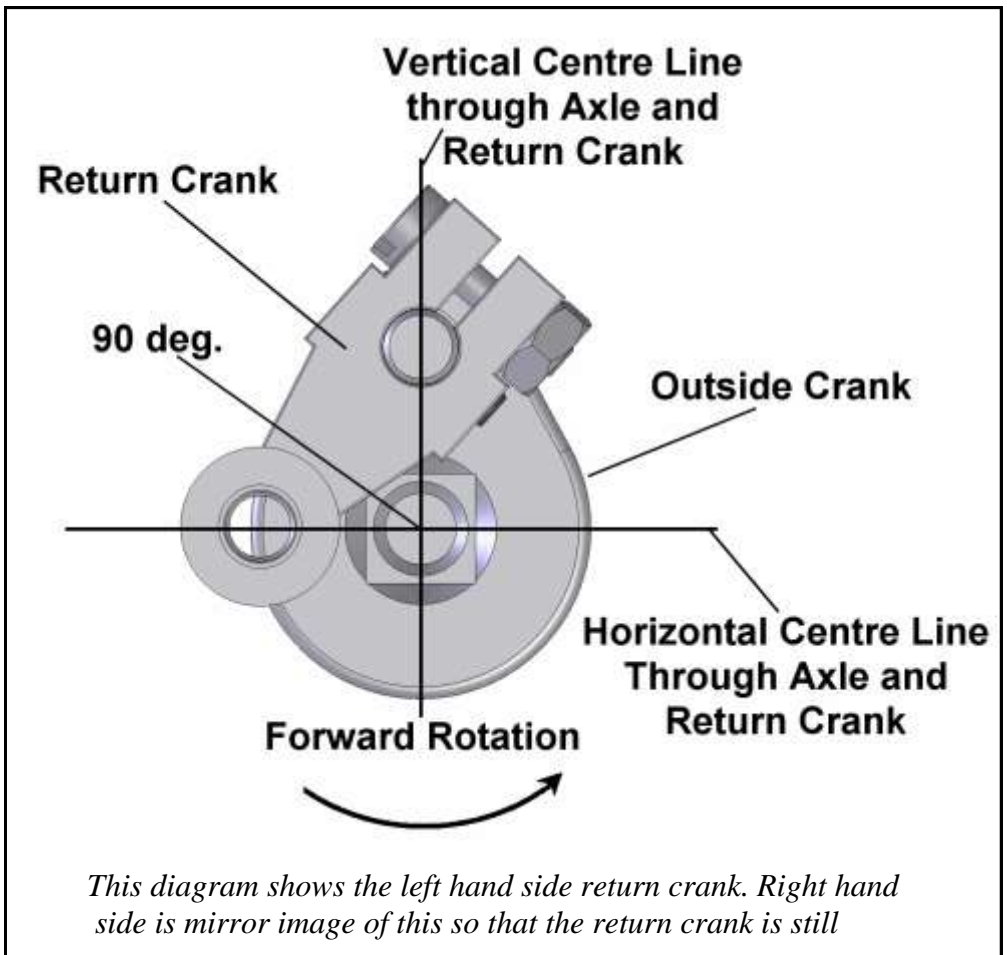

between. The thicker end goes to the rear with the 'joggle' outwards. This is a good point to check that everything works freely when the wheels are rotated. Check for tight spots or anything miss-aligned.

Now onto the radius rods.

Before fitting, the crank pins, which form the slide block in the expansion link, have to be prepared. This simply entails screwing one into the tapped hole in the thick end of the radius rod and filing off the excess thread, which sticks through at the rear. File the thread off flush to the back then remove the screw again.

Take the prepared crank pin, fit a steel washer then pass it through the curved slot in the expansion link and screw it into the tapped hole in the radius rod. Note that the radius rod is also 'joggled'. This time the 'joggle' should be inwards to bring the thinner end of the radius rod nicely in line with the valve spindle on the cylinders.

Fit the thinner end into the forked end of the valve rod and screw the steel screw (supplied with the cylinders) through the hole to connect up.

You now have the main links connected and rotating the wheels with the radius rod at the bottom of the curved slot in the expansion link should result in the valve in the cylinders being moved backwards and forwards.

What is needed now is a means of raising and lowering the radius rod and holding it in position so we now must assemble the lifting links etc.

Slide the left hand lifting arm onto the left-hand end of the weigh shaft. Note that the lifting arms are handed and the left hand has a second arm which points upwards and slightly forwards for attaching the reversing rod.

Using the M2 steel screws, connect the lifting arm to the radius rod. The screws pass through the

holes in the arm and radius rod and screw into tapped holes in the lifting links. Do not tighten the screws, but leave a small gap to allow for movement as the lifting gear operates. Fit an M2 steel nut to the screws at the back of the lifting link and tighten these up.

The reversing rod and 'Quicklink' can be used to hold things in position while they are pinned. Screw the 'Quicklink' onto the end of the reversing rod and attach it to the lifting arm (the one pointing upwards) by springing the ends open, pushing the pin through the hole in the arm and then letting it close.

Set the valve-gear to mid gear, that is, operate the lifting arm until the hexagon screw, which drives the radius rod and slides up and down in the expansion link is exactly in the centre of the curved slot. Check this by rotating the wheels and watching the radius rod. There should be no fore and aft movement whatsoever. Keeping it in this position, clamp the end of reversing rod to the side of the chassis with a toolmakers clamp or similar.

Double-check the position of the radius rod.

Now, turn the weigh shaft until the bow in it is at the bottom. This bow is to clear the underside of the boiler and bear in mind that it will swing through a small arc as the valve gear is moved from forward to reverse.

Tighten the grub screw in the top of the lifting arm boss to lock it in place.

Keeping everything clamped in place, assemble the right hand lifting arm and link and set that side to mid gear.

Hold the links in position and tighten the grub screw as before.

Take great care with this operation and ensure that the radius rods on both sides are exactly in mid gear, or they will be lifted unevenly when the lifting arms are operated.

The valve-gear is now assembled and we can move on to timing before finally pinning the return cranks in position.

### Valve Timing

This is adjusting the valve position so that it opens and closes at the correct time and is checked visually by watching the valve movement.

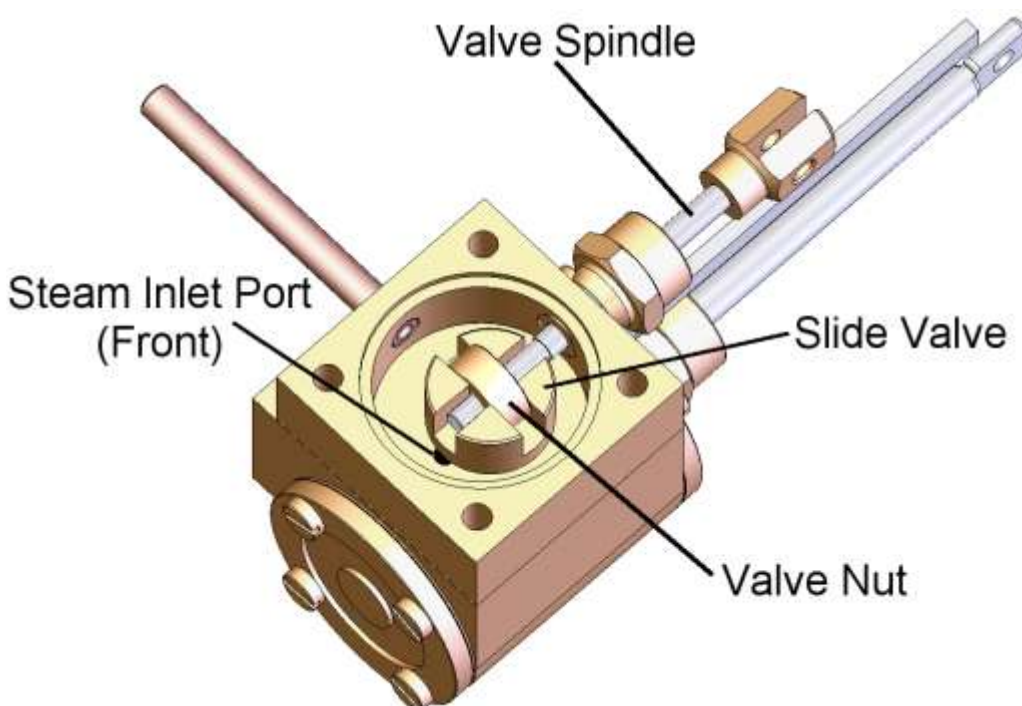

With the valve-gear still clamped in mid gear, look down into the valve-chests and note the position of the slide valves. They should be sitting centrally over the steam inlet ports, covering both. If they are not, disconnect the radius rod from the valve spindle fork end and rotate the valve spindle to screw the slide valve in the desired direction.

Re-connect the radius rod and re-check position. There may be a small amount of fore and aft free

movement of the valve if the spindle is moved with the fingers, which just uncovers the steam ports. If this is the case, adjust the valve position so that the ports are opened an equal amount when moved thus. Repeat this with both sides until the valves are correctly positioned.

Un-clamp the end of the reversing rod and move it forward so that the radius rods are lowered in the expansion links. Position them near but not right at the bottom and clamp the reversing rod in place again. The gear is now set for forward running so, rotate the wheels by hand in a forward direction and watch the slide valve movement.

The edge of the steam ports should become visible (crack open) as the crank pin on the drive axle is at dead centre. The front steam port should be cracking open at front dead centre and the rear steam port at rear dead centre.

If the return cranks are correctly positioned, this should be the case. If not, rotate the return crank on the crank pin a very small amount and re-check.

When satisfied that the timing is as close as you can get it, the valve chest covers can be fitted. Place a second 'O' ring into the top recess of the valve chest. Ensure that the 'O' ring seals between the cylinder blocks and the valve chests, and between the valve chests and the valve chest covers, are fully in their respective recesses before tightening down the valve chest covers. The chassis can be test run on compressed air if available to check operation. Don't forget that the radius rod should not be raised or lowered right to the ends of the expansion link slot and use plenty of oil on all working parts. Slight unevenness in running can normally be overcome by slight adjustments when the locomotive is running under its own steam - see fine tuning.

When you are satisfied that the timing is correct and the chassis runs smoothly in both directions, the return cranks should be drilled and pinned to ensure that they do not move in service.

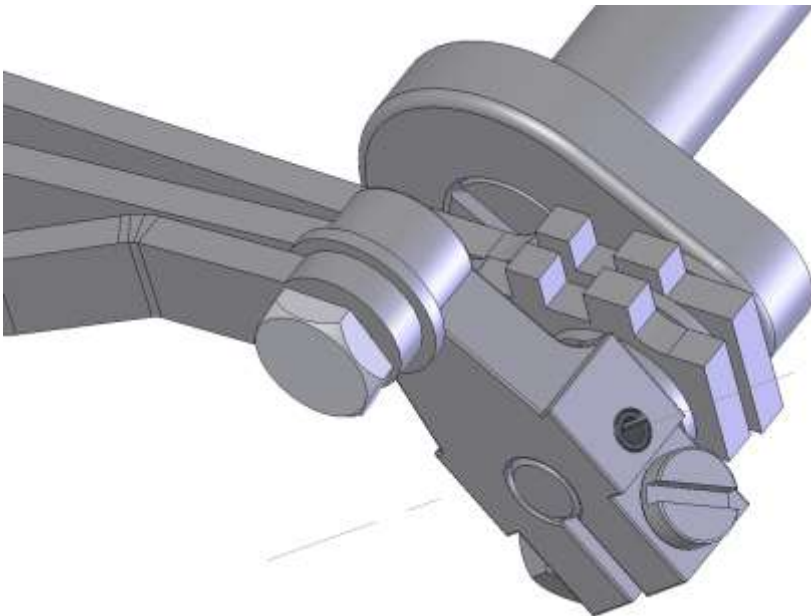

Place the chassis on the worktop and rotate the wheels to position the outside crank towards the top of its movement, with one of its sides sitting horizontal. Place a 3/4" thick block of wood underneath the return crank to support it. Using a sharp 1.6mm drill, drill a hole vertically downwards through the centre of the return crank, through the crank pin and out of the bottom. Push a roll pin through this hole to lock this side in place then repeat for the other side. Ensure that the return cranks do not move during this operation.

**Note**, If you do not have your superheater fitted and are therefore unable to test the running of your chassis at this stage, do not pin the return cranks in place. Wait until you are able to carry out a test run.

### Reversing Lever

A set of parts are included to construct a reversing lever for manual operation that can be mounted on the footplate. Refer to the diagram below which shows how the reversing lever is assembled. Check that the Reversing Lever Arm is orientated as shown in the diagram below. Then attach the push rod connector to the Reversing Lever Arm with the Starlock Washer as shown. Place the spring over the Long Crank Pin and push the threaded end of the Long Crank Pin through the hole in the bottom of

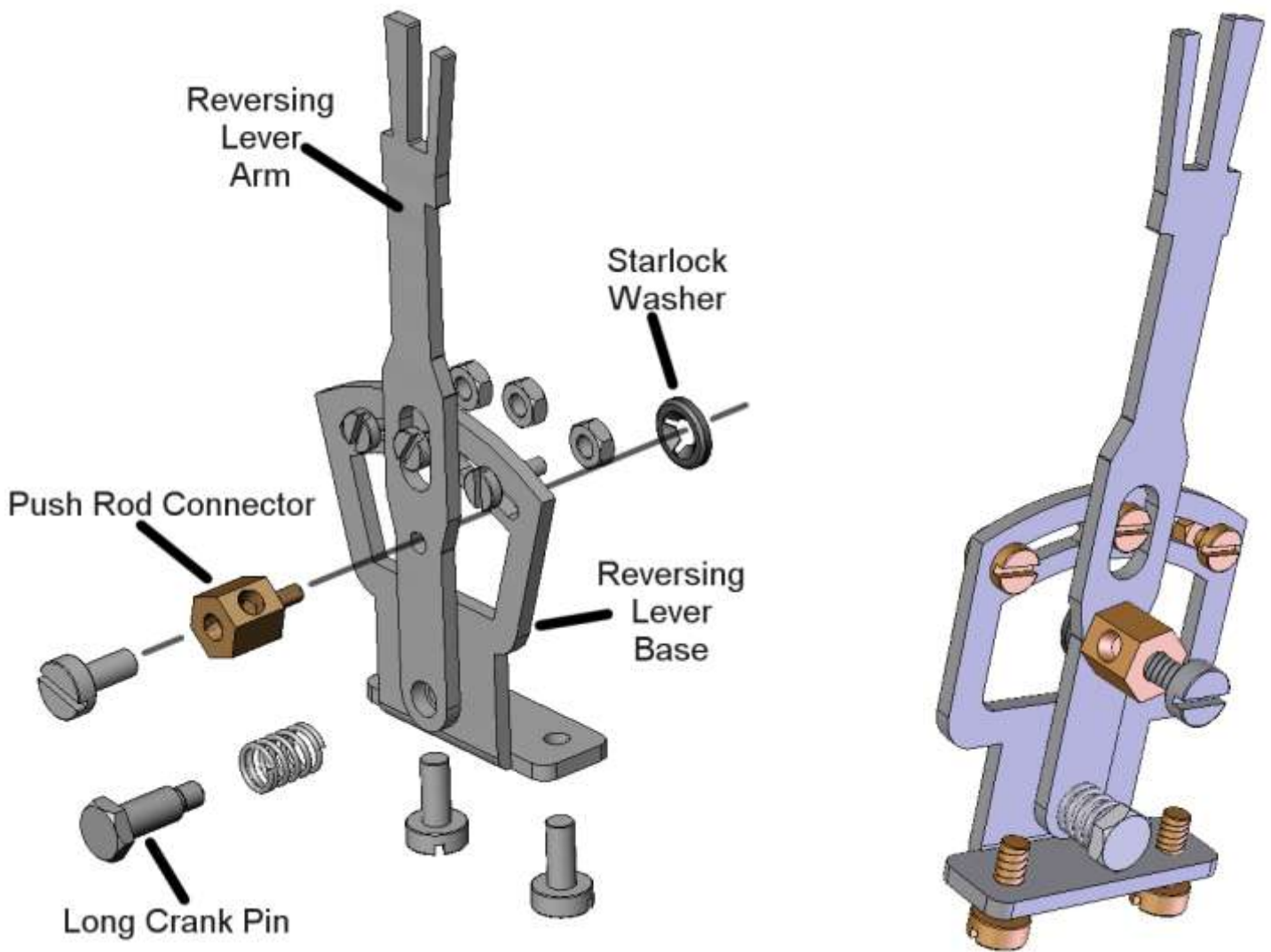

the Reversing Lever Arm and screw into the threaded hole in the Reversing Lever Base. Fit an M2 screw and nut to the top central hole in the Reversing Lever Base which will allow the Lever to stay at mid gear. Now fit an M2 screw and nut to either side of the lever. This will allow you to move the valve gear between Forward, Reverse and Mid-Gear. The exact position of these screws can be determined by running the chassis or loco on blocks and moving the lever as it is running until the optimum position is found.

The assembly should be securely fixed to the chassis or footplate using the M3 brass screws so that the valve-gear is held firmly in gear. The reversing lever should be fitted so that the reversing lever arm and the push rod connector are facing towards the inside of the cab - they will foul on the cab side if fitted the other way around. If a **ROUNDHOUSE** body kit is to be used, mounting holes are provided on the cab footplate so, to test run the chassis at this stage, simply clamp the end of the reversing rod to the chassis as previously described.

Adjust the lever for smoothest running in both forward and reverse then tighten the stops accordingly.

### Fine Tuning

When the locomotive is capable of running on the track under its own steam, that is, after the boiler etc. has been fitted, the timing can be fine tuned for best performance.

Please note that it will require running under steam for several hours before it reaches its best performance. This is because all the working parts have to 'bed in' properly. Initially, steam will leak past the slide valves to a greater or lesser extent, but this will eventually stop as the two surfaces 'bed in' and form a good working seal. The first few hours of running therefore may well be a little stiff and jerky at slow speeds and lacking in power.

It is a good idea to run the chassis supported on blocks for a couple of hours before progressing to the track test and adjustments. Use plenty of oil on all working parts.

Set the loco off on a reasonably level length of track at a slow speed. If it stalls, note the position of the drive crank pins if either is at front or rear dead centre. Repeat this several times and it will soon show up if there is a 'dead spot' at any particular point of the valve cycle. If, for instance, it keeps stalling with one particular crank pin just after rear dead centre then this would indicate that the slide valve is opening a little late. Disconnect the radius rod and rotate the valve spindle half a turn to move the slide-valve forwards a fraction as detailed in valve timing earlier. Re-connect the radius rod and try the loco again in both directions to check that your adjustment has not simply removed that dead spot only to replace it with a different one.

A short time spent running the engine and making any adjustments just half a turn of the valve spindle at a time should soon show its optimum positions.

### **Radio Control**

This valve-gear is ideal for operation by radio control and a kit of parts is available for full two-channel (reverser and regulator) operation of the locomotive. If however, you are fitting your own equipment, a suitable horn must be fitted to the servo, which gives a very short movement. Remember that the radius rod does not move the full length of the expansion link between forward and reverse and a little trial and error is needed to match this movement to that of the servo.

### **Maintenance & Trouble Shooting**

The following section is only relevant once the boiler is fitted as full testing can only be done under steam.

When new, the cylinders will require running for several hours before they reach their full performance as the slide valve must 'bed in'. A cylinder lubricator must be fitted to ensure that there is an adequate supply of steam oil at all times.

The piston rod and valve spindle glands are fitted with 'O' rings and should not be over-tightened. If a steam leak develops just nip up the gland nut enough to stop the leak and no more. Over-tightening will have an adverse effect on running.

The piston is also fitted with an 'O' ring which can be easily replaced if it becomes worn or damaged.

Cylinder covers are sealed by gaskets, and valve chest joints are sealed by 'O' rings. Any leaks which develop here during the first few hours of running can usually be cured by simply tightening the relevant screws. **Note** that these are small screws and will break if over-tightened - be careful.

Because the slide valves are held onto the port faces by steam pressure, it is possible for small particles of dirt, lime scale etc. which are carried through with the steam, to become lodged between the two and thereby break the seal necessary for operation. This would show up as excess amounts of steam being exhausted up the chimney with a continuous hiss coupled with loss of power or failure to run at all. The remedy is quite simple and involves removing the valve chest cover, lifting the valve chest just enough to remove the slide valve from the side and cleaning the valve and port face. The valve face can also be 're-made' to remove any score marks etc. by carefully rubbing it on a piece of fine emery paper or whet & dry paper placed on a very flat surface. Make sure that you hold the valve perfectly flat down onto the abrasive and remove a very small amount at a time. Take care not to rotate the valve spindle or nut and replace the slide valve the same way round as it was and there will be no need to reset the valve timing. Squirt a little steam oil into the valve chest as you replace the parts to help lubricate and seal the valve.

If all is operating correctly, when running the locomotive slowly, you should hear the separate beats of the exhaust up the chimney as the valve opens and closes.

If, when hot, the chassis seems to stiffen up, re-check the following, because, as stated earlier, expansion can alter the fit of something you thought was OK when cold.

Is there still a little side play in the axles? The outside cranks may be pressing on the axle bushes.

Do the wheels still rotate freely without sticking at front or rear dead centre? The coupling rod holes may need a little more attention with the file.

### Technical Help

You should now have a running chassis and a better knowledge of what makes a steam locomotive work. If not, don't despair. **ROUNDHOUSE** offer technical help over the phone during normal working hours, or email us at [support@roundhouse-eng.com](mailto:support@roundhouse-eng.com)

- we will do our best to get you through any difficulties.

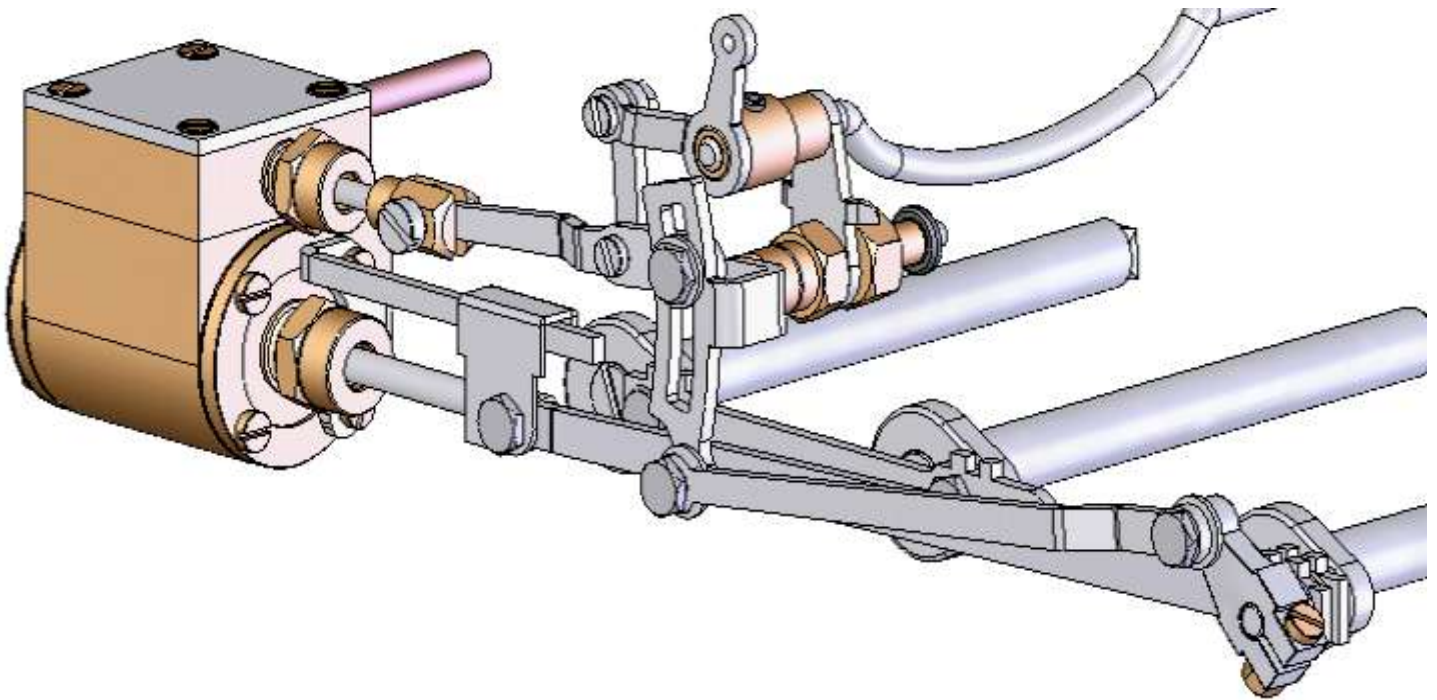

## **ROUNDHOUSE ENGINEERING CO. LTD.**

Units 6-9 Churchill Business Park. Churchill Road.

Wheatley. Doncaster. DN1 2TF. England

Telephone 01302 328035 Fax 01302 761312

e-mail [support@roundhouse-eng.com](mailto:support@roundhouse-eng.com)



[www.roundhouse-eng.com](http://www.roundhouse-eng.com)



# HBK2 Lady Anne Chassis Kit

## CHECKLIST

- 1 Pair mainframes with axle bushes fitted.
- 1 Pair buffer beams.
- 1 Steel push rod & Quicklink connector.

- 2 Return Cranks with screws & nuts.
- 2 Eccentric rods.
- 2 Expansion links expansion link bushes & nuts.
- 2 Starlock washers.
- 2 Weigh shaft brackets.
- 1 Weigh shaft.
- 2 Lifting arms with grub screws and Allen Key (M3 x 1.5mm).
- 2 Lifting links.
- 2 Radius rods.
- 2 Roll pins.
- 6 Short crank pins.
- 8 5BA steel washers.
- 4 M2 steel screws & nuts.

- 1 Frame spacer (plain).
- 1 Frame spacer (with centre hole).
- 1 Frame spacer (with centre tapped hole).
- 3 Frame spacers (with two tapped holes).
- 3 Axles.
- 4 Plain outside cranks.
- 2 Outside cranks with crank pins fitted.
- 2 Coupling rods.
- 2 Connecting rods.
- 1 Wheel back to back gauge and Allen Key (4BA).

- 2 Centre Buffers.
- 4 Short crank pins.
- 8 5BA steel washers.
- 6 4BA steel CSK screws.
- 18 M3 brass CH screws.
- 2 M3 brass CSK screws.
- 4 M3 brass nuts.
- 3 1/4 " bore steel washers.

- 1 Push Rod Connector, Screw & Starlock.
- 1 Stainless Steel spring & Crank Pin.
- 1 Reversing lever handle.
- 1 Reversing lever base.
- 3 M2 screws and nuts.
- 2 M3 mounting screws.

- 1 Pair of Cylinder blocks, inc front cover, piston assembly, slide bar and exhaust pipes fitted.
- 4 Socket screws and washers.
- 4 Valve chest 'O' rings.
- 2 Valve chest assemblies, inc valve rod and valve nut fitted.
- 2 Slide valves.
- 2 Steel Valve chest covers.
- 8 Brass countersunk valve chest screws.
- 2 Crossheads and short crank pins.
- 2 Steel 6BA x 1/4" screws.
- 1 Allen Key (2.5mm) for cylinder screws.

- 4 Flanged driving wheels.
- 2 Flangeless driving wheels.
- 6 Grub screws for wheels (in wheels).

- 1 Set of BA pressed steel spanners.

PARTS CHECKED