

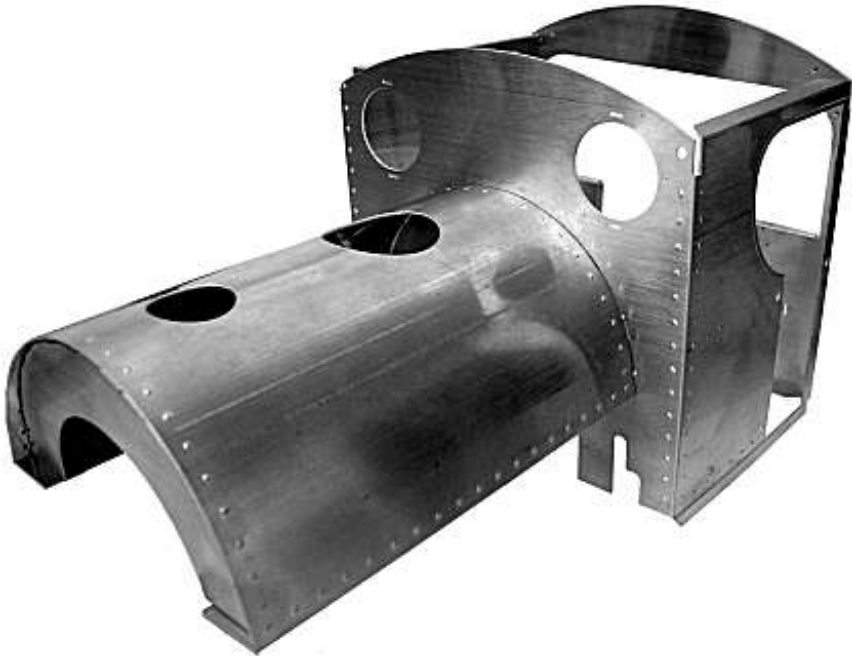

**Modular Locomotive System  
Instruction Manual  
for  
HBK17 Katie Body Kit**



**Roundhouse Engineering Co. Ltd.**

Unit 6 to 9 Churchill Business Park  
Churchill Road, Wheatley  
Doncaster. DN1 2TF  
ENGLAND

Tel. 01302 328035 Fax. 01302 761312

Email: [support@roundhouse-eng.com](mailto:support@roundhouse-eng.com)

**[www.roundhouse-eng.com](http://www.roundhouse-eng.com)**

# **HBK17 BODY KIT FOR 0-4-0 CHASSIS AND BOILER.**

## **INTRODUCTION**

These instructions cover the construction of the body kit intended to fit the HBK15 & HBK16 chassis and boiler kits.

All parts are included to build the locomotive as the factory built 'Katie'.

The brass panels are photo etched to shape and all fold lines and holes are etched into the parts where necessary.

Only a minimum of cleaning up is required and will normally simply mean running around the edges with a small file or emery cloth. As a general rule, all folds should be 90 degrees with the etched lines on the inside of the angle except if specifically stated otherwise.

The kit is designed for either manual or radio control operation and all fixing holes are provided for both versions.

The panels have been designed for assembly with soft solder, however, if preferred holes can be drilled at the joints and small rivets or screws used. If soldering, a small to medium butane blowtorch is ideal, as the large areas of brass work will dissipate the heat of a soldering iron too quickly unless a very powerful one is used. Use a suitable flux with the solder, Bakers fluid being particularly good, though extreme care must be taken during use.

Follow the manufacturers instructions on the packaging at all times. Glue of any kind is not suitable for the main structure, but is required for such items as the tank filler base, etc. 'Araldite', 'Devcon' or a similar epoxy adhesive are ideal for this purpose.

Refer to diagrams where necessary and hold parts together with small clamps such as toolmakers clamps or miniature G or C clamps, during soldering or drilling of joints. It is advisable to run through the full instructions identifying all parts and mountings and have a 'dry run' before soldering anything in place.

All painting is left to the builder and Acrylic paint is readily available in spray cans for a good finish. A good primer is essential and if available an etch primer should be used on brass parts. A good model shop will stock more specialised paints and should include etch primer in the range. Read carefully and follow the maker's instructions that appear on the can before using any paint. All parts must be thoroughly cleaned and rubbed down with fine wet and dry paper prior to painting.

## CAB LAYOUT

This diagram below shows the layout of the cab fittings on the finished model, having previously constructed the HBK15 and HBK16 kits.

The version shown is manual controlled.

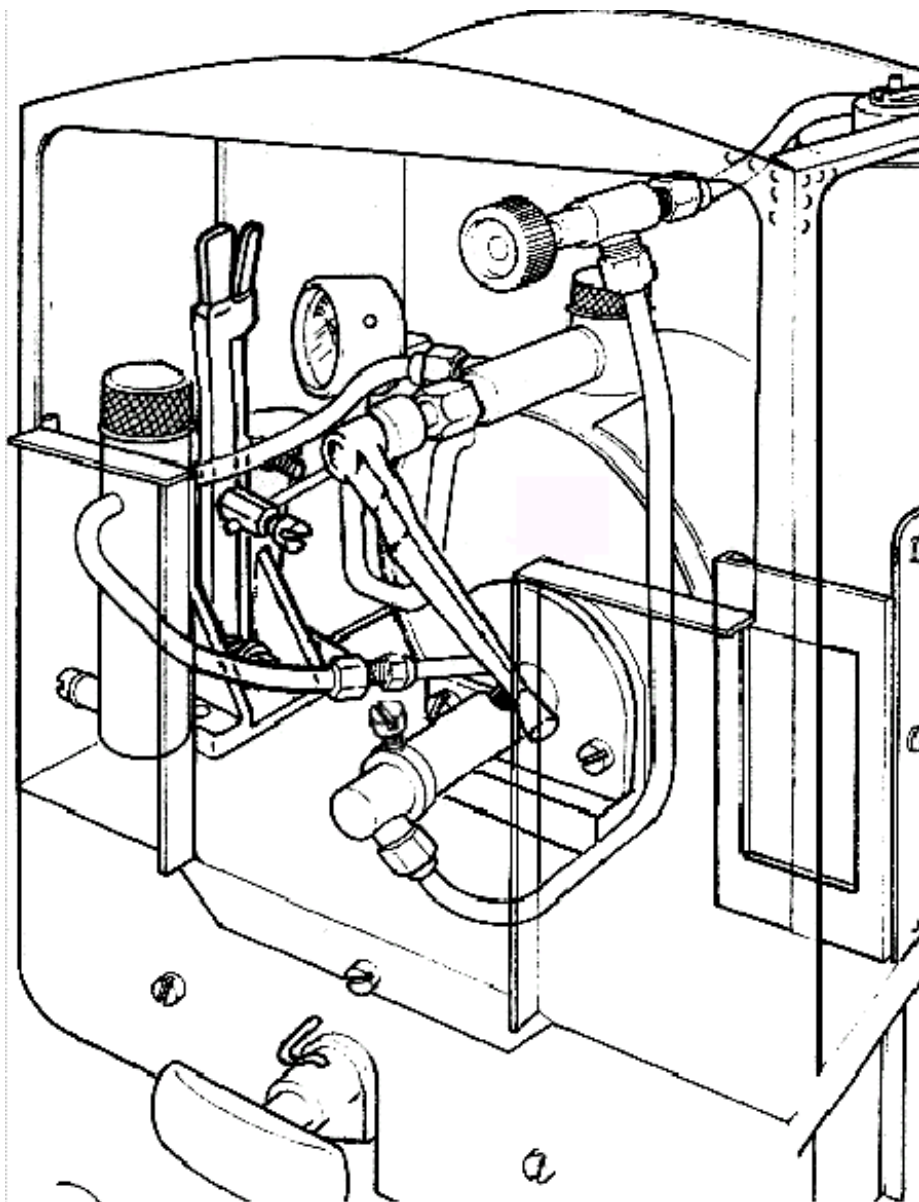

## **CONSTRUCTION.**

If you have already constructed the Katie Chassis and Boiler kits HBK16, one boiler band holding the boiler mounting foot, and the boiler wrapper will already be fitted to the boiler. We now need to fit the saddle tank fixing band around the boiler wrapper. If the chassis/boiler is complete, it will be necessary to remove the lubricator, gas tank and gas burner.

Unscrew the two union nuts that connect the lubricator to the regulator and superheater. The lubricator can now be put to one side. Unscrew the union nut that connects the gas pipe to the gas regulator. Remove the two screws that attach the gas burner to the back of the boiler bracket. The gas burner can now be removed and also placed to one side. Remove the two screws and locknuts that hold the gas tank to the chassis enabling the gas tank to be removed.

Unscrew the M3 fixing screw that attaches the rear of the boiler to the rear frame spacer and remove this screw and the spacers underneath.

The boiler can now be pulled backwards out of the smokebox - the cab end of the superheater may need to be straightened slightly if the boiler does not easily slide over the superheater.

Curve the Saddle Tank Fixing Band around the boiler. Place the band around the boiler so that it is about 1 1/2" from the smokebox end of the boiler, and the ends of the band come together on the left hand side of the boiler. The band is secured using an 8BA x 1/2" screw and nut. Don't tighten the screw too much at this stage, as the band may have to be adjusted to align with the saddle tank.

## FOLDING LONG SECTIONS OF BRASS

When folding long brass sections such as the side flanges of the cab floor, it is better to hold the flanges between two pieces of angle iron in a vice or clamps, as illustrated below. In this way, the entire flange is bent over in one movement and results in a much neater finish.

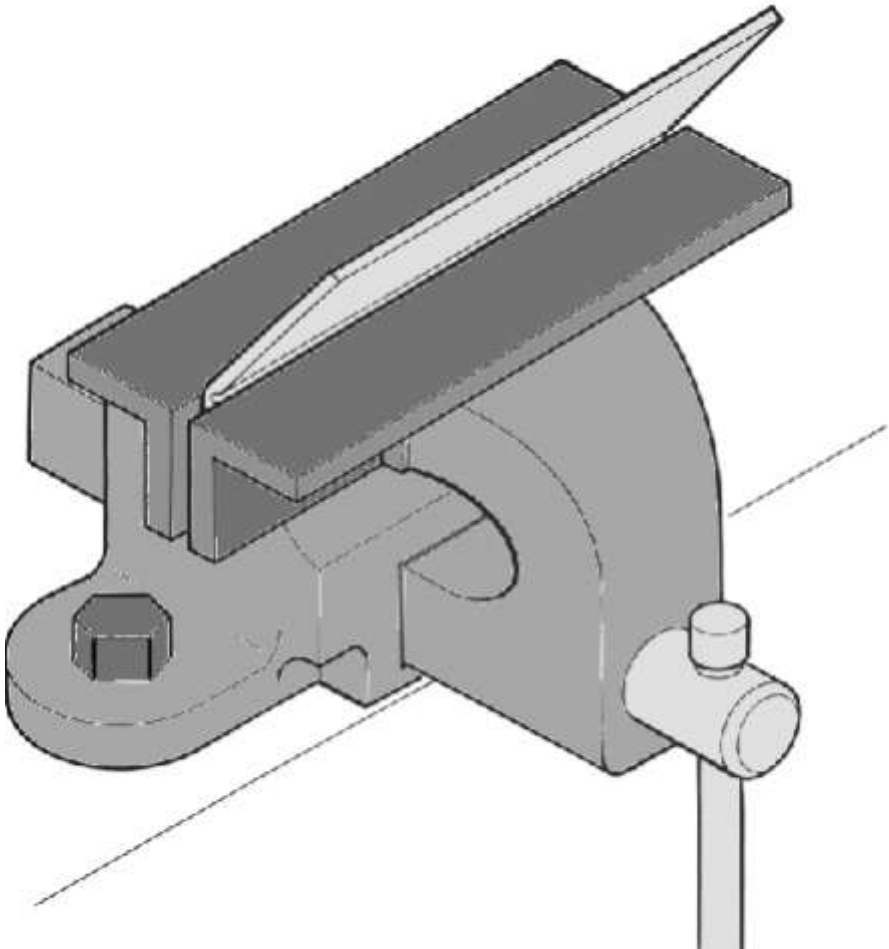

## CAB FLOOR

Before the cab floor is fitted, it must first be folded.

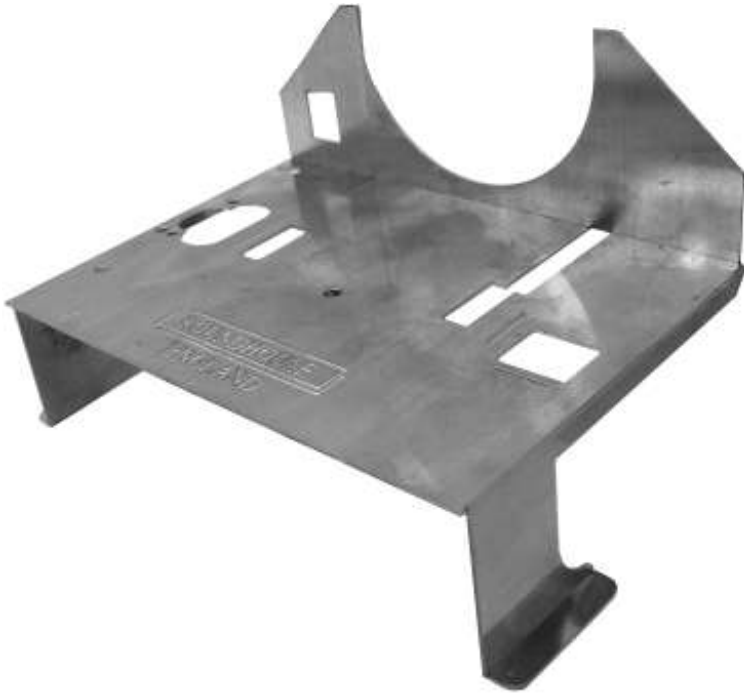

When folded into shape, the cab floor should appear as shown in the diagram above. Ensure that the ROUNDHOUSE ENGLAND logo that is etched into the brass remains to the top when finished.

Fold the front of the cab floor 90° so it points upwards at a right angle.

The flanges and cab steps should now be folded downwards at 90°, and the lip at the bottom of the step then folded outwards to form the step.

If you intend to radio control the model later, the bracket that will hold the cab servo can be fitted. It should be bent and fitted to the cab floor as shown below. The tags on the bottom fit through the slots in the cab floor. These tags can then be bent over underneath and soft soldered to the cab floor.

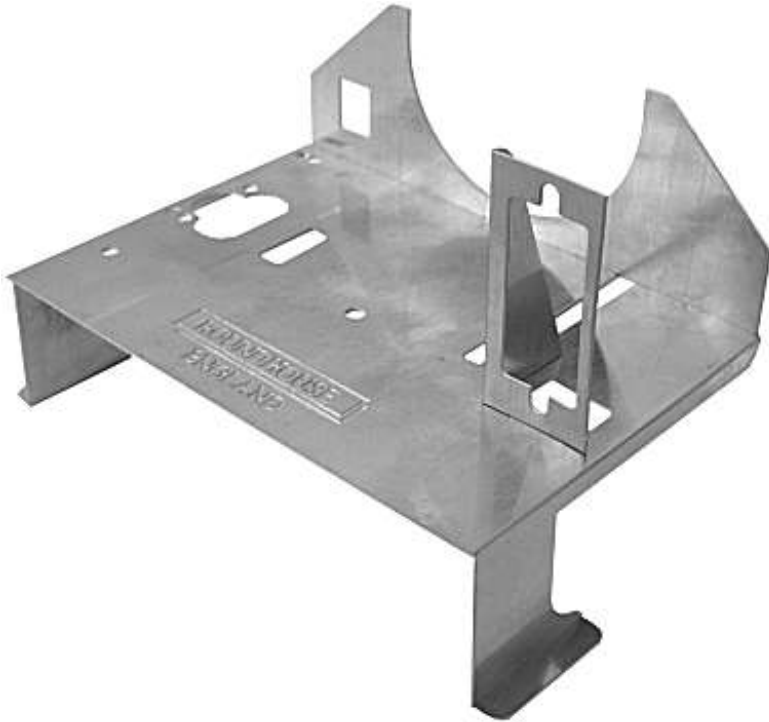

The floor can now be painted and fitted to the chassis. Lay the cab floor on the chassis so that the rear edge of the floor is level with the rear buffer beam and the hole in the frame spacer is visible through the hole above the ROUNDHOUSE logo.

The boiler can now be refitted using the M3 screw that was removed earlier.

The gas tank may now be refitted. There is a slot in the cab floor that allows the gas tank mounting bracket to pass through. It is attached to the chassis as before using the two brass screws and locknuts.

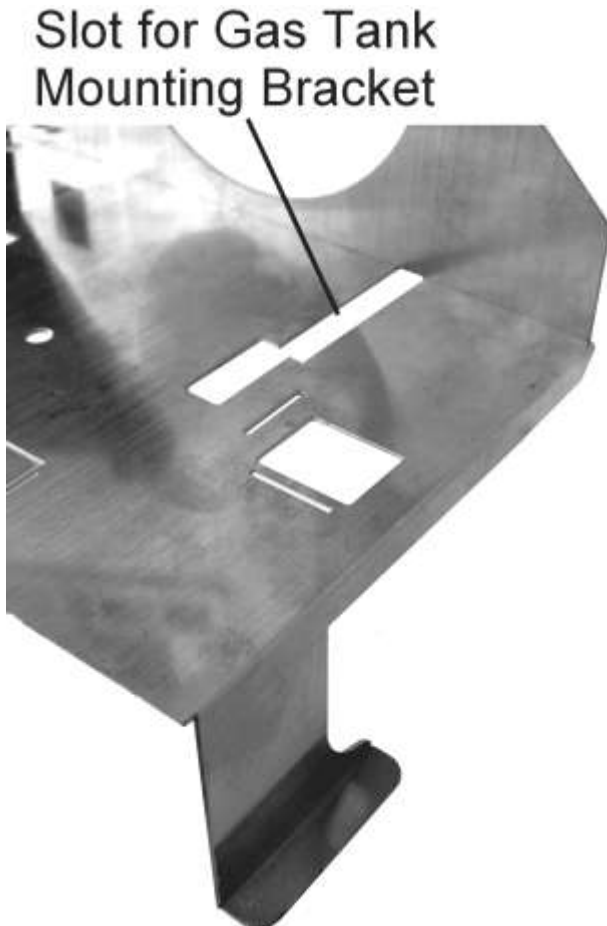

The gas burner should now be replaced using the two brass screws. The gas pipe should now be reconnected to the gas regulator. The pipe may require bending slightly to avoid the servo bracket.

The reversing lever should now be fitted to the cab floor with its brass screws through the holes identified below.

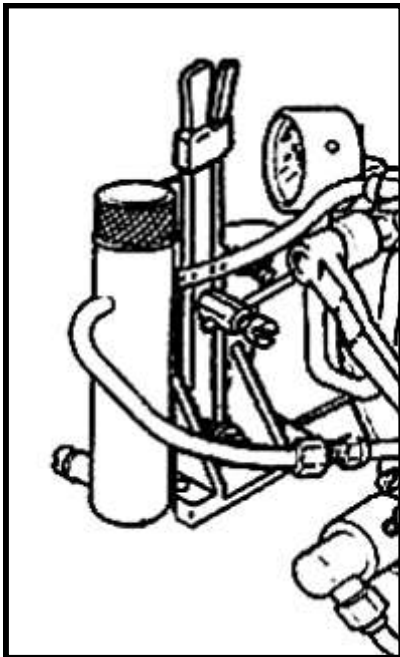
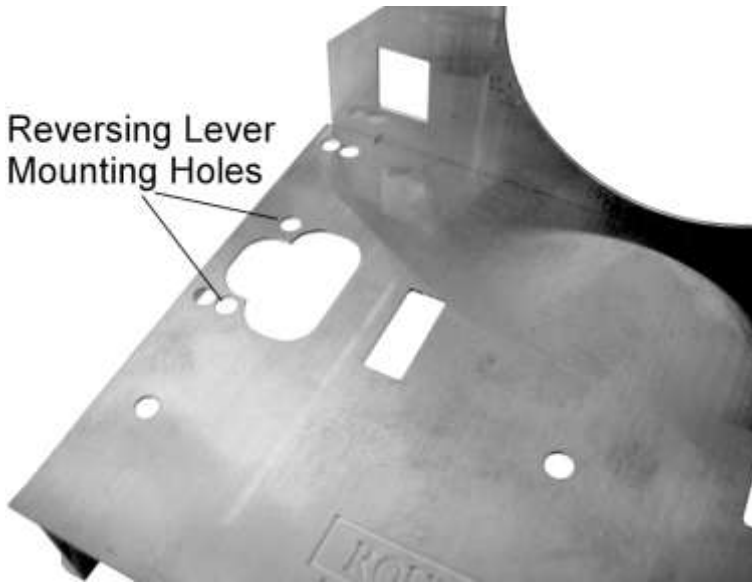

Refit the lubricator. It should be positioned centrally above the cab step, with the drain screw overhanging the cab floor slightly.

Ensure that the lubricator pipe that connects to the superheater does not protrude over the rear buffer beam, as this will foul the body when we come to fit this later.

## CAB BODY

We will now start to work on the main body. Quite a lot of folding is required, and you will remember from the introduction the general rule regarding this: -

*All folds should be 90 degrees, with the etch lines on the inside of the angle except where specifically stated otherwise.*

Bearing this in mind, fold the 6 panels numbered 1 to 6 in the diagram below. Panels 1 to 4 are folded outwards whilst panels 5 and 6 are folded inwards.

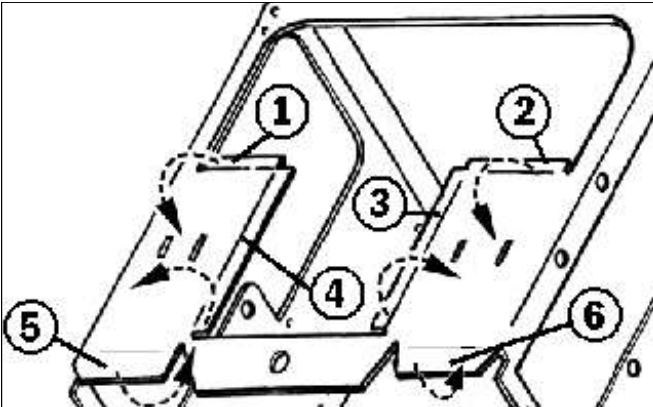

The picture on the right shows the cab back after the panels have been folded.

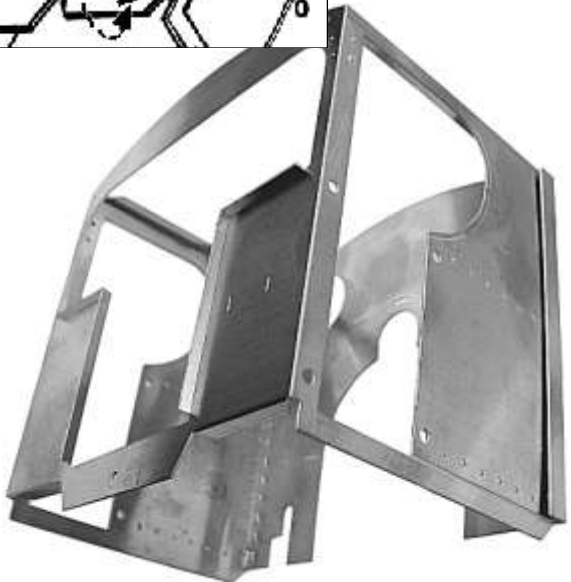

We now need to fit the Saddle Tank Front into the Saddle Tank. Push the saddle tank curved front into the end of the saddle tank. It should be inset from the edge by about 3mm so that the reverse side of the rivet detail is just visible - see the picture below.



We are mainly concerned that the top of the arc is correctly positioned at this stage, as we will clamp the two pieces together here. Use a small G clamp or C clamp as shown in the picture below, and apply a small amount of solder just at this top point.

After soldering at the top, remove this clamp. Next, using two clamps, clamp both the bottom edges of the front to the bottom of the saddle tank. Make sure that the sides of the saddle tank are as close to the sides of the curved front as possible, and that the curved front follows the rivet detail so that it is set at an even distance



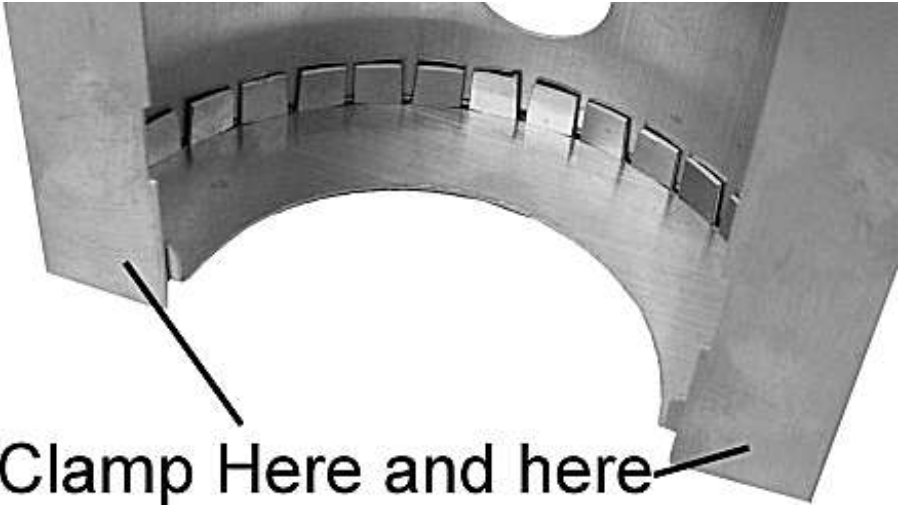

from the front of the saddle tank. Run some Bakers fluid around the outside joint so that when you solder from inside the solder will be pulled through to form a neat joint.

Put the saddle tank to one side while the cab is soldered. Clamp the cab as shown below, check that the joint is held square and solder along the length of the joint.

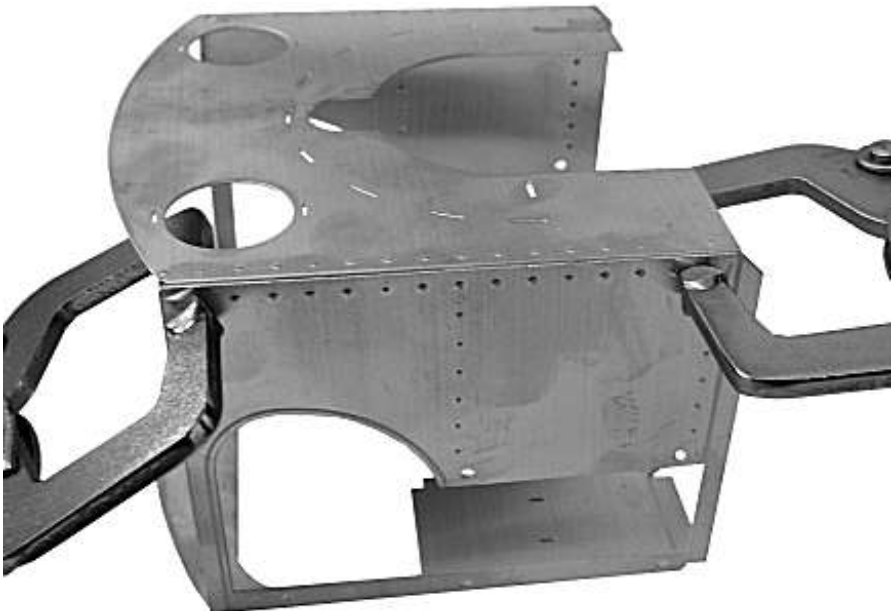

When the cab is cool enough to handle take the saddle tank and carefully push the tags at the back through the corresponding slots in the cab front. It is best to leave the clamps on the cab body in place to avoid the risk of the joint here springing apart as the saddle tank is soldered into the cab. Bend the tags downward so that the saddle tank is fixed in position. The tags can now be soldered. If you run some Bakers fluid around the front where the saddle tank meets the cab, solder should be pulled through and form a neat joint here.

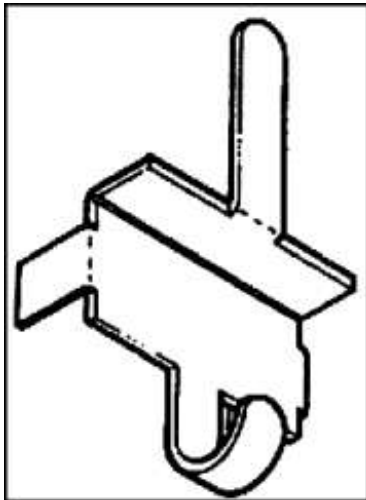

Fold the lamp brackets as shown in the diagram to the left. The side tabs can then be pushed through the rear of the body in the slots provided as shown in the diagram on the right. The tabs can then be bent over and then soldered in place.

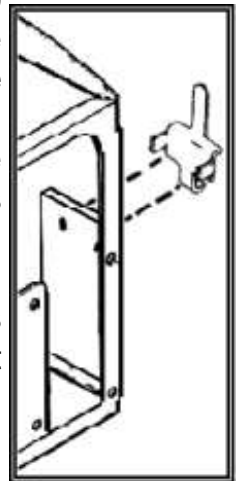

We are almost ready to paint the completed body. Now is a good time to prepare the completed body prior to painting. Refer to the instructions in the introduction.

Before painting the body, but after the body has been prepared, fit the white metal Tank Filler Base into the smaller of the two holes in the top of the saddle tank. Use an epoxy glue such as Araldite.



## Roof

Fold the cab roof hinge as shown in the picture below right, and attach it to the underside of the cab roof using two 8BA countersunk screws and nuts. Countersink the holes on the top of the roof that these screws pass through, so that the head of the screw is flat with the roof. The hinge has slotted holes to allow for adjustment of the roof position. Check roof and hinge position on top of the cab and tighten the screws up. File away any excess thread that protrudes through the nut. The roof may now be painted and put to one side until we are ready to fit it to the completed body.

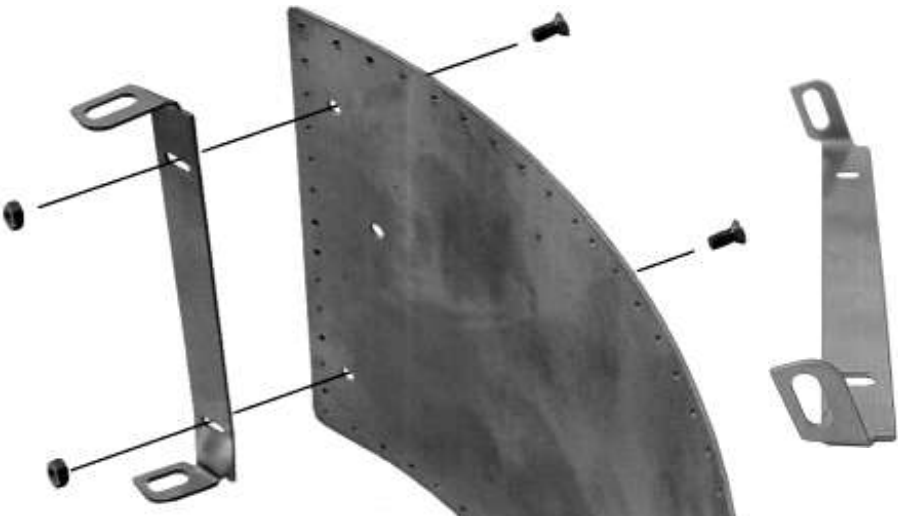

## BODY FITTINGS

When the body is completely dry, spectacles, handrail knobs and handrails can be fitted.

The two tags on each spectacle should be folded back at right angles - the etched detail should be to the front. The spectacles can now be fitted to the cab front by pushing the tags through the slots provided. The tags are then simply bent over on the inside. They do not require soldering or gluing.

The eight handrail knobs should be fitted as shown in the diagram below. They are secured with 8BA nuts from the inside. It is easier to slide the handrails into the handrail knobs if they are left slightly loose at this stage. Slot a handrail through the holes in the top and bottom handrails, check that it is positioned correctly and tighten

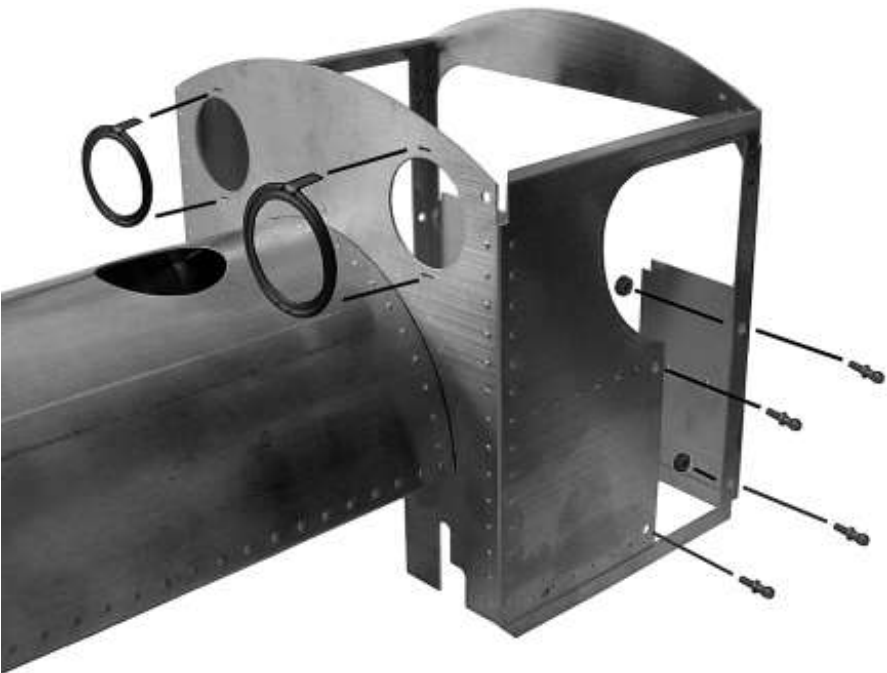

up the 8BA nuts. Usually they will hold in place perfectly well, but if they do become loose they can be secured by glue or Loctite 601.

The brass Dummy Injector can now be fitted. This simply slots into the rectangular hole underneath the right hand side of the saddle tank, near the cab. The two 'pipes' should point towards the cab. Put a small amount of glue into the slot in the injector and hold in place with a little tape until the glue has set.



Before fitting the body, the reversing lever should be connected to the lifting arm. Pull the lifting arm backwards into reverse gear and pull the reversing lever fully backwards. Check the length of rod needed and remove any excess. The rod may now be connected to both the reversing lever and lifting arm and checked to ensure even movement. It is important that the radius rod does not move completely to the top or bottom of the expansion link. Set the 8BA screws that act as stops, in the reversing lever so that a small gap (about 1/16") is left at the top and bottom of the expansion link slot

The exact position of the stops can be determined by running the chassis or loco on blocks and moving the lever as it is running. Adjust the lever for smoothest running in both forward and reverse then tighten the stops accordingly.

## **FITTING THE BODY**

The completed, painted body can now be fitted. Carefully place the body over the gas tank and lubricator. Remove the lubricator drain screw. The left hand side may need to be eased over the lubricator drain. Check that it is square and seated correctly all round.

At the front of the saddle tank, check that the hole through the Tank Filler Base lines up with the Saddle Tank Fixing Band boss, and use the 4BA countersunk screw to secure the front of the saddle tank. The brass tank filler can now be dropped into the Tank Filler Base.

A 6BA x 3/16" brass screw should be used to secure the bottom rear of the cab to the rear buffer beam.

The cab roof is attached by an 8BA screw, washer and nut at either side. These screws both pass through from the outside with a washer between the cab and the hinge, and a nut on the inside. These screws and nuts should be left slightly loose to allow the hinge to operate. A spot of 'Loctite' or, if this is not available, paint, on the threads will prevent the nut from coming off. The dummy whistle sits on top of the roof over the small hole at the front, centre. Push a 8BA x 3/16" brass screw through the hole from underneath, and screw into the whistle to secure.

Finally, the brass dome simply sits over the safety valve assembly.

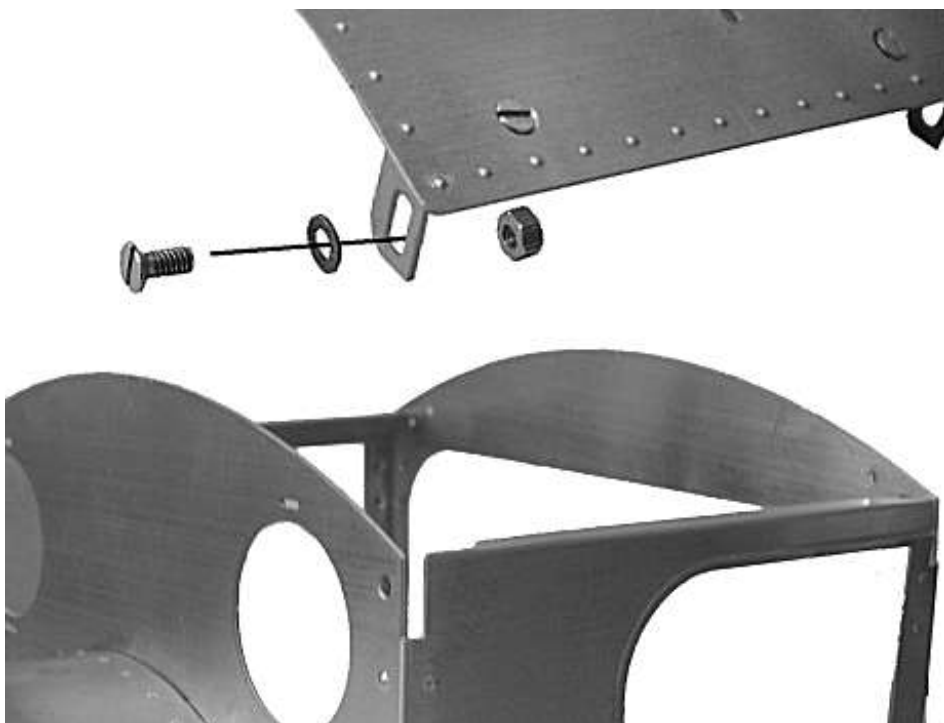

# HBK17 CHECKLIST

- 1 Cab body panel (folded)
  - 1 Cab floor
  - 1 Saddle tank (pre rolled)
  - 1 Saddle tank front
  - 1 Servo Bracket
  - 1 Roof
  - 1 Roof hinge
  - 1 Saddle tank fixing band with screw & nut
  - 1 Brass dome
- 

- 2 Brass spectacles
  - 2 Brass lamp brackets
  - 1 Saddle tank insert (white metal)
  - 1 Brass dummy tank filler
  - 1 Dummy whistle
  - 1 Cast brass dummy injector
- 

- 8 Brass handrail knobs
  - 4 Brass handrails
  - 3 8BA X 3/16" brass screws
  - 2 8BA x 3/16" brass countersunk screws
  - 1 4BA x 3/16" steel countersunk screw
  - 1 6BA x 3/16" brass screw
  - 2 Small brass washers
  - 12 8BA nuts
- 

*Checked*