

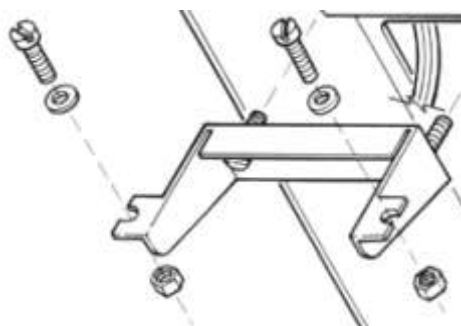

**Modular Locomotive System**  
**Instruction Manual**  
for  
**HBK 10 Lady Anne R/C Fittings Only Kit**



**Roundhouse Engineering Co. Ltd.**

Units 6-9 Churchill Business Park

Churchill Road, Wheatley

Doncaster. DN1 2TF. England.

Tel. **01302 328035**

Fax. *01302 761312*

Email. [support@roundhouse-eng.com](mailto:support@roundhouse-eng.com)

**[www.roundhouse-eng.com](http://www.roundhouse-eng.com)**

# **HBK10 Lady Anne R/C Fittings Only Kit**

## **Introduction**

These instructions cover the fitting of radio control to the HBK2/4/6 Lady Anne locomotive kit and contains all brackets, fixings etc. to enable the builder to fit his or her own radio equipment.

Roundhouse locomotives are fitted as standard with 'Hitec' or 'Futaba' radio equipment and all fixings and brackets are designed for this. If using radio equipment from another manufacturer, ensure that it is of similar specification to the items mentioned in these instructions or problems could be encountered.

Modern 40MHz digital proportional radio control equipment should be used as this gives fine control with the minimum of interference.

Before starting assembly, check contents against the list and read through the instructions fully, referring to diagrams where necessary, so that you identify all parts and understand where each is fitted.

## **HBK10 Contents**

- 1 Aerial plate (dummy roof vent) with Spade terminal
- 1 Battery holder
- 1 Battery connector clip with leads (PP9 type)
- 1 Reversing control rod with Quicklink, locknut & Starlock washer
- 2 Reversing servo mounting posts
- 1 Etched brass regulator servo mounting bracket
- 1 Regulator control rod with Quicklink and locknut
- 1 Heavy duty pushrod connector with screw & starlock washer
- 1 Steam regulator (r/c type)
- 1 Regulator arm
- 1 Strip of double sided sticky pads
- 1 4½ inches (115mm) large (4.8mm) shrink wrap
- 1 2 inches (50mm) small (2.4mm) shrink-wrap
- 6 M3 Brass CH screws
- 2 6BA x 1/4" CH screws
- 2 6BA nuts
- 2 M3 Nuts
- 2 Washers
- 2 8BA x 3/16" csk. Screws
- 2 8BA nuts
- 2 Plastic cable ties.

### **You will need to supply**

A two channel radio control set complete with transmitter, receiver, switch harness and two standard servo's (Hitec HS-300, HS-303, Futaba FP-S148 or equivalent). If multi-channel equipment is used, only two channels will be required for this locomotive.

## Construction

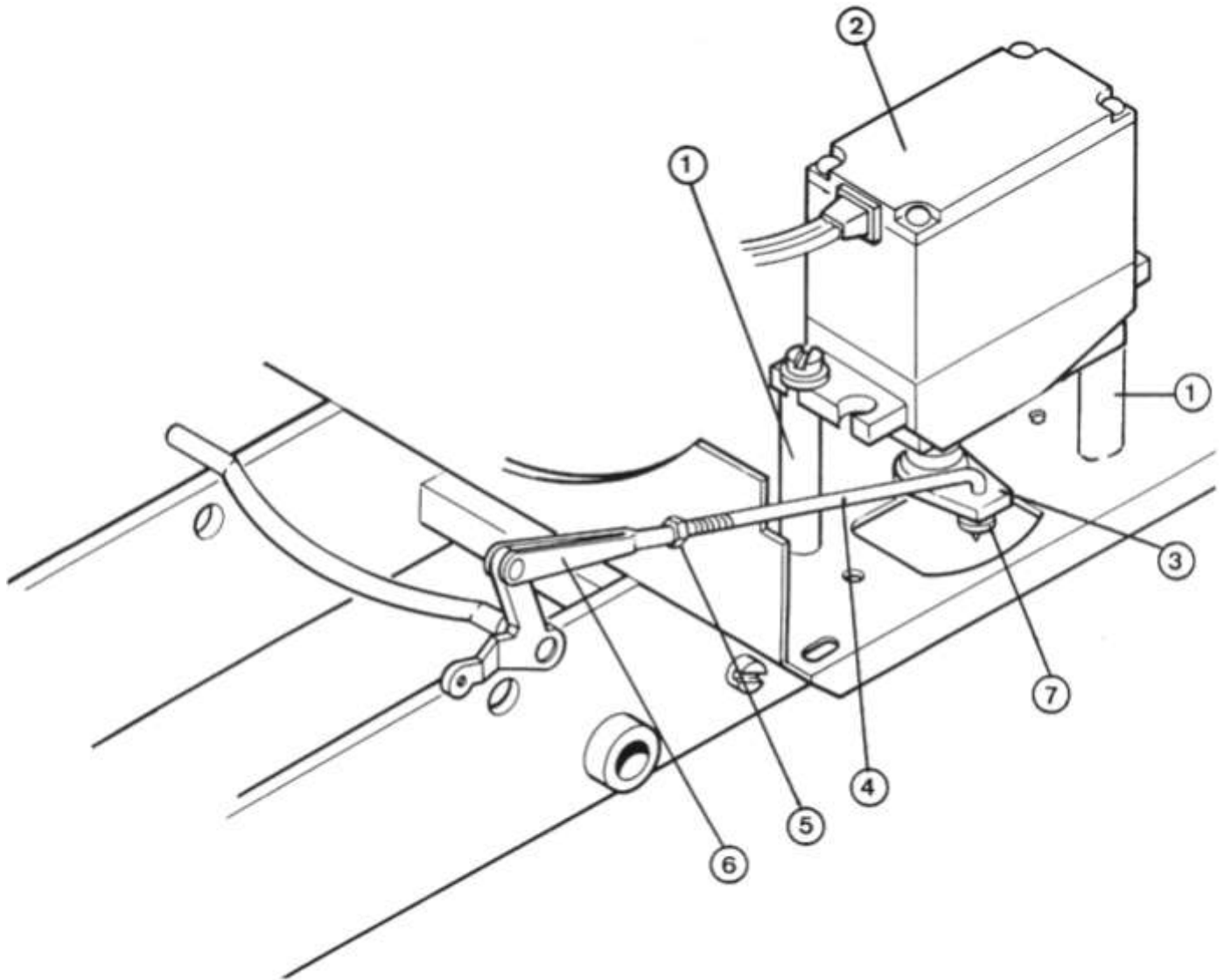

**Diagram 1 Reversing Servo**

*1/ Reversing servo mounting posts. 2/ Reversing servo. 3/ Short servo horn.  
4/ Reversing control rod. 5/ Lock nut. 6/ Quicklink. 7/ Starlock washer.*

The reversing servo for operating the Walschaerts valve-gear should be fitted first. The servo mounts on to the left hand side of the foot plate with the three coloured lead to the front, using the two brass posts, four M3 brass screws, nuts and washers (on the top screws only) as shown in diagram 1.

Note that the front post uses the inner mounting holes and the rear post uses the outer mounting hole, thus supporting the servo on diagonal corners.

Do not fit the horn or linkage at this time.

Fold up the etched brass regulator servo mounting bracket as shown in diagram 2 and solder two 6BA x 1/4" brass screws up through the two holes in the top mounting flange. These must be soldered in place, as they will be used to fasten the unit up through the cab floor and are not accessible from underneath.

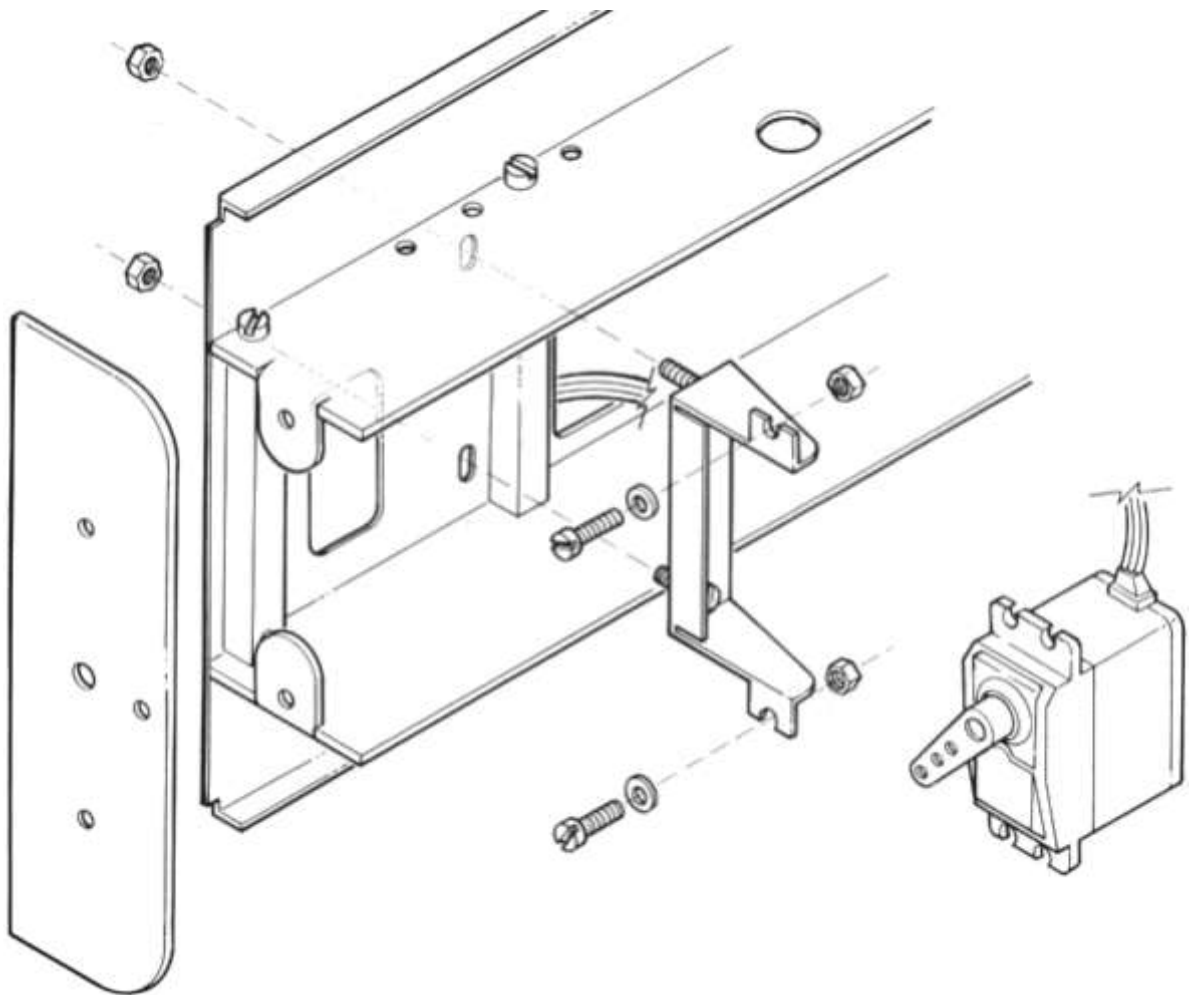

***Diagram 2***  
*Regulator servo mounting bracket*

---

The bracket can now be painted if required.

Before fitting the bracket to the servo, the mounting lugs on either side of the servo must be trimmed down slightly to allow it to fit snugly between the main frames.

Fit the servo into the bracket and fasten with two M3 brass screws, washers and nuts and trim off the washers flush with the edge of the servo.

The assembly can now be fastened up to the under side of the cab floor using two 6BA nuts onto the previously soldered screws. Note that the three coloured lead is to the right hand side of the chassis and can be passed up through the large rectangular hole in the footplate immediately above it.

Do not fit the horn or linkage at this time.

The switch can now be fitted to the right hand foot plate (diagram 3) using the cut-outs provided. The switch body sits on top of the foot plate with the slider pointing down for access from underneath. One of the switch leads (see manufacturers hand book for details) will plug into the receiver, do not alter this. The other lead will go to the battery and must be modified to connect to the new battery holder supplied in this kit. The overall length of this battery lead must be extended by attaching the PP9 type battery clip and lead to it. A distance of 12" (305mm) from the switch body to the beginning of the PP9 clip is required.

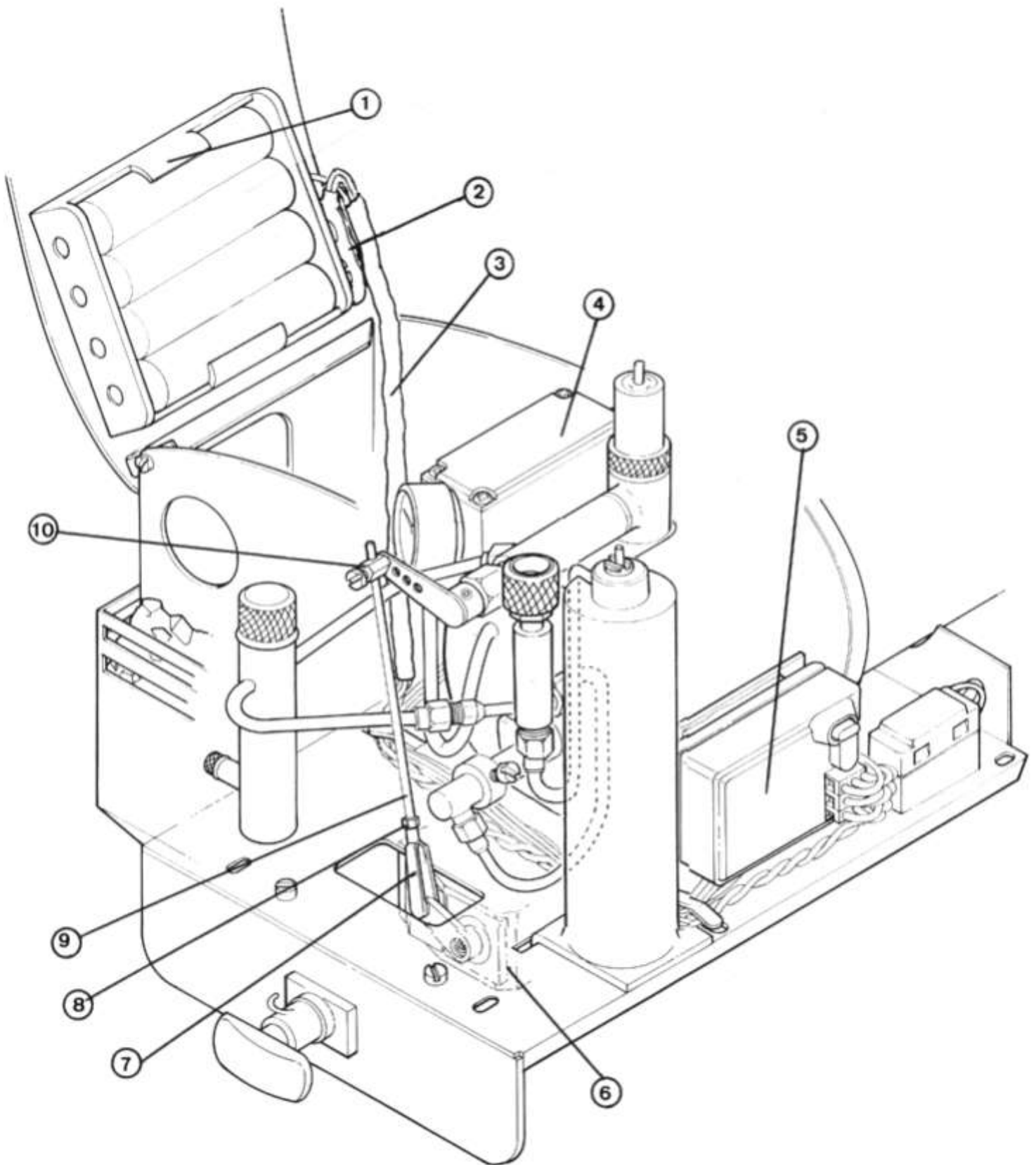

**Diagram 3 General Layout**

*1/ Battery clip. 2/ PP9 type connector. 3/ Shrink wrapped leads.  
4/ Reversing servo. 5/ Receiver. 6/ Regulator servo. 7/ Quicklink.  
8/ Lock nut. 9/ Control rod. 10/ Heavy duty push rod connector.*

Switch harnesses from different manufacturers vary in length and type of plug and socket used to connect their normal battery holder. It is often easier just to cut the plug/socket from the end of this lead and attach the PP9 lead, but check lengths before doing so. Take the PP9 type battery clip and

slide the 4.5" (115mm) long piece of large diameter shrink wrap over the leads which are attached to it but do not shrink it yet. This lead can now be soldered to the end of the battery lead from the switch, but first you must prepare the joint as follows. Two short lengths of the small diameter shrink wrap about 1/2" (13mm) long should be cut from the 2" (50mm) piece supplied, to insulate the soldered joints.

Shrink wrap is a special rubber tube, which reduces in diameter when heated, To use it, first slide it over the end of one of the two wires to be joined and away from the wire end. After the wires are soldered together, slide it back to cover the exposed joint and overlap the insulation a little at each side. Finally, rub the hot soldering iron over the shrink wrap and it will close tightly round the joint. Ensure that both red wires and both black wires are connected together.

Using a couple of double sided sticky pads, fix the receiver to the vertical plate alongside the boiler, between the switch and the gas tank. The aerial wire should be uncoiled and threaded through the large diameter shrink wrap alongside the battery lead

In order to set and adjust the linkages, the r/c equipment must be connected up and batteries fitted. A tag is provided, etched into the foot plate, on each side of the engine to retain the leads. These should be bent up slightly by pushing from below.

First, the reversing servo lead should be positioned as follows. Down the outside of the servo - on the inside of the rear mounting post - under the left hand retaining tag - across the cab floor - under the right hand retaining tag - forward beneath the receiver and finally into the socket marked (1).

The regulator servo lead should be brought up through the hole in the floor, pass round and under the right hand retaining tag then forward beneath the receiver and into the socket marked (2).

The long battery lead and aerial wire should pass under the right hand retaining tag, across the cab floor and under the left hand retaining tag.

The short battery lead with the three-pin plug should be plugged into the receiver in the socket marked BATT or (B).

All loose wires, except the long battery/aerial group, can be tidied up using the cable ties supplied. Ensure that none are in contact with hot pipes or fittings and out of the way of any moving parts.

Now that the main items are installed, we can fit and adjust the linkages, first however, the spring which self-centres the left-hand (regulator) control arm on the transmitter, needs removing. The right hand control (reverser) can be left sprung loaded to centre as this gives a convenient mid-gear position.

Refer to manufacturers instructions regarding the removal of this spring as details vary on different makes of radio control equipment. On the Hitec three channel transmitter, there is a small white button on the back labelled 'QUICK START'. This is a useful function for racing cars but potentially dangerous in our application, as it operates the regulator servo when pressed. As a safety precaution, so that it does not accidentally get pushed whilst running the engine, this can be unscrewed from the panel and taped up safely inside the transmitter while you have the back off to remove the spring.

You should now have the left hand control lever (facing you) unsprung and capable of being left in any position and the right hand lever sprung to the centre.

When the transmitter modifications are complete, fit the required batteries to it.

Fit four batteries in the receiver battery clip then connect the battery clip to the end of the battery lead from the switch.

Switch on both transmitter and receiver.

Moving the right hand control lever should now cause the reversing servo to operate and moving the left-hand lever should cause the regulator servo to operate. If this is not the case, check all connections and batteries.

Set the reversing servo up first as follows.

Prepare a servo horn so that it has a single arm with a connecting hole approx. 8mm from the centre. If none of the arms supplied with your r/c set have a suitably positioned hole, you will have to drill one using a 1/16" or 1.6mm drill. The position of the hole is quite critical as it will effect the travel of the radius rod in the expansion link, but as different makes and types of servo have slightly different angles of movement, it is not possible to give exact measurement, - some trial and error is required.

Ensure that the control lever on the transmitter is in the centre and that the trimmer (small black lever below the main lever) is also in the centre then push the servo arm onto the servo pointing out from the chassis at 90 degrees and fix in place with its retaining screw. This has now set the servo horn for mid gear and moving the control lever either way will move the horn accordingly. Set up the transmitter, using the servo reversing switch if necessary, so that moving the lever to the left engages forward gear (moves horn forwards) and to the right engages reverse (moves servo horn to the rear).

Screw the 8BA lock nut and Quicklink onto the reverser control rod then fit the kinked end down through the hole in the servo horn and push the Starlock washer up over the end to retain it. The star lock washer is a tight fit and should be fitted with care, supporting the top of the horn whilst pushing it on, or damage may occur to the horn. Fit the Quicklink over the vertical arm on the weigh shaft by springing open the end of the Quicklink and passing the pin through the hole in the arm as shown in diagram 1.

The linkage must be adjusted so that when the servo is set to mid gear, the radius rod is roughly in the centre of the curved slot in the expansion link. Now, check for movement to full gear in both directions and make fine adjustments to the linkage by screwing the Quicklink along the control rod until the radius rod moves an equal amount either up or down the expansion slot.

Note that the radius rod should not travel the full length of the expansion link, but should stop a small distance from either end. On some Hitec transmitters we have an extra refinement to aid us in this setting in the form of three extra 'trimmers'. The left hand one, labelled 'Throttle Quick Trim' can be ignored, as this now has no function. The other two, labelled 'CHI ATV CH2' control the amount of rotation of the two servo spindles and 'CH 1' can therefore be used to adjust the maximum raising and lifting of the radius rod.

A replacement r/c type regulator is supplied with this kit. Although externally it looks the same as the manual type supplied with the boiler kit, internally it is quite different. It is designed to operate with a servo where a small amount of movement must give full control from closed to fully open. It also relies on an 'O' ring to ensure that it closes fully with the minimum of force.

Although the standard needle valve supplied with the boiler can be used with radio control, its operation, particularly in closing fully, is not always reliable.

Fitting of the r/c type regulator to the boiler is the same as for the manual type and is described fully in the boiler kit instructions.

The rear buffer beam should be removed to allow setting up and adjustment of the servo linkages. Prepare the regulator arm by fitting the heavy-duty pushrod connector to the fourth hole. Push the spigot through the hole from the front and push the Starlock washer over the spigot to lock it on. Fit the screw in the end of the connector loosely.

Prepare a servo horn with a single arm and four connection holes.

Set the left-hand control lever on the transmitter to the bottom and ensure that the trimmer at the side of it is at the top. This will park the servo in its normally closed position.

Fit the servo horn so that it is pointing to roughly halfway between 10 and 11 on a clock face and fix it in place with the small screw provided. When the left-hand control lever is moved upwards, the servo horn will rotate anticlockwise. If it travels clockwise, use the servo reverse switch on the transmitter then reset the horn as above.

Turn the regulator spindle clockwise with your fingers to close it, but do not force it. Fit the

regulator arm to the spindle placing it roughly parallel to the servo horn and nip up the grub screw using the same Allen key supplied for the wheel grub screws. Using the straight linkage, Quicklink and locknut, connect the regulator arm to the servo horn as shown in diagram 3. The Quicklink should fit in either the 2nd or 3rd hole on the servo horn.

Setting and adjustment of the regulator is best done with the locomotive in steam and with the chassis supported on two wooden blocks under the chassis to raise the wheels off the bench. Ensure that the regulator is closed when raising steam.

With full working pressure raised, switch on both transmitter and receiver and move the locomotive into gear with the right hand lever on the transmitter. Open the regulator by slowly moving the left-hand lever upwards and find the position at which the engine starts to run. Move the arm backwards and forwards a few times to establish the position at which it closes and leave it there. If the regulator does not open or fails to close fully, slacken the grub screw holding the regulator arm in place, remove the arm and turn the spindle manually (careful as its hot!) to find the point at which it just closes. Move the control lever on the transmitter to the bottom and replace the regulator arm. Proceed as before to find its closing position and leave it there. Carefully slacken the grub screw and move the control lever to the bottom without moving the spindle. Nip up the grub screw. You can make fine adjustments to the linkage now until the regulator closes fully with the control lever at the bottom. Because of the 'O' ring used in the r/c type regulator, you should aim for the wheels to start moving when you have moved the control lever on the transmitter about halfway up. This is because the 'O' ring will compress slightly into its seat when fully closed. You may need to adjust the position of the arm on the spindle, the control rod in the push rod connector, or both to achieve this. You should also check that when fully open, the servo horn does not protrude below track level. Trim off any excess servo horn to ensure that this does not happen. When satisfied that all is adjusted correctly, tighten all screws, switch off the gas burner and r/c equipment and disconnect battery clip.

The trimmer at the side of the control arm can be used in the future to compensate for wear and compression of the 'O' ring. As time passes, you may find that the regulator does not fully close when the control lever is at the bottom. As this happens, the trimmer can be moved down a little at a time to compensate.

When you are satisfied that the adjustment is correct, the rear buffer beam can be replaced.

The locomotive body can now be refitted, ensuring that the battery/aerial lead passes up inside the front left-hand corner of the cab.

Remove the four batteries from the clip and, using two 8BA x 3/16" countersunk screws and nuts, fix the battery clip to the underside of the cab roof. It is necessary to drill two small holes, 2.3mm diameter, in the plastic battery clip, one at each side. Two countersunk holes are provided in the cab roof and if you offer the battery clip up before drilling, you will see that your holes need to be right at the edges of the clip so that the nuts that will be inside do not interfere with the batteries. The connector for the PP9 type clip should be to the front and left for connecting to the battery lead. Check position carefully so that the cab roof closes fully without the battery holder, clip or wires fouling anything.

The dummy roof vent is used as the main aerial. The long tab on one side should be covered with shrink wrap as described earlier, leaving about 6mm on the end uncovered, then curved over at 90 degrees so that it passes down through the large hole in the front of the roof next to the dummy whistle. Stick it to the cab roof using four double sided sticky pads. These pads are to insulate it from the roof, so ensure that there is no contact between any part of it and the roof. Check particularly where it sits over the heads of the battery clip fixing screws and round the dummy whistle. Any metal to metal contact will short circuit the aerial and cause interference with the radio signal.

With the battery clip connected and the cab roof hinged up, coil up the excess aerial wire using a cable tie or similar, leaving enough to connect to the end of the long tab from the dummy roof vent with the spade connector, and place near the receiver. Solder the spade connector to the end of the aerial wire and insulate the complete connector and soldered joint with shrink-wrap. The spade connector can now be pushed onto the roof vent tab to complete the installation.

Ensure that all links etc. have been tightened and that all wires are safely and securely routed. The final job is to remove the body and heat up the shrink-wrap protecting the battery lead and aerial wire.

This concludes the fitting and adjustment of the radio control equipment.

---

## **HBK10 Checklist**

- 1 Aerial plate (dummy roof vent) with Spade terminal
- 1 Battery holder with Battery connector clip and leads (PP9 type)
- 1 Reversing control rod with Quicklink, locknut  
& Small Starlock washer
- 2 Reversing servo mounting posts
- 1 Etched brass regulator servo mounting bracket
- 1 Regulator control rod with Quicklink and locknut
- 1 Heavy duty pushrod connector with screw  
& Small Starlock washer
- 1 Steam regulator (r/c type)
- 1 Regulator arm
- 1 Strip of double sided sticky pads
- 1 4½ inches (115mm) large (4.8mm) shrink wrap
- 1 2 inches (50mm) small (2.4mm) shrink wrap
- 6 M3 Brass CH screws + 2x M3 Nuts
- 2 8BA x 3/16" csk. Screws + 2 x 8BA nuts
- 2 6BA x 1/4" CH screws + 2 x 6BA nuts
- 2 Washers
- 2 Plastic cable ties.

