



DARJEELING 'B' CLASS



Owners Handbook

Operating Instructions

IMPORTANT: Read these instructions carefully before operating the locomotive

The following items are required for running this engine and are not included with the model.

Fuel Butane gas. See 'Filling the gas tank'

Water See 'Filling the boiler'

Lubricating oil See 'Lubrication'

SAFETY PRECAUTIONS

This is a working model locomotive using steam under pressure and highly flammable fuel. Provided it is operated with reasonable care and attention, no problems should arise.

It is intended for use out of doors and must only be operated in a well-ventilated area.

Whilst the locomotive is in use, hot gasses are exhausted up the chimney and excess steam frequently blows off through the safety valve even when stationary, so operator and spectators should not bend over the model.

As you will appreciate, this is not a toy and is therefore unsuitable for young unsupervised children.

Follow manufacturers recommendations regarding the safe storage of Butane gas canisters.

Some areas of the model will get quite hot whilst it is operating, so a pair of gloves are provided in the tool kit for your protection.

Always have to hand either a fire extinguisher or wet cloth when operating the model.

Darjeeling 'B' Class Instruction Booklet



CONTENTS

Tool kit	Page 4
Un-packing the model	Page 4
Running in	Page 5
Access to controls	Page 5
Identification of parts of the locomotive	Page 6
Preparations for operation	Page 6
1. Filling the Gas Tank	Page 6
2. Filling the Boiler	Page 7
3. Lubrication	Page 8
4. Lighting the Burner	Page 9
Running the locomotive	Page 10
Driving manually	Page 10
Driving by radio control	Page 11
Water top-up system	page 12
Trouble shooting & maintenance	Page 14
Storage between operating sessions	Page 14
Steam leaks	Page 14
Regulator not shutting	Page 14
Radio control	Page 15
Gas system	Page 15
Service and parts.	Page 20
Boiler and Gas Tank Certificate, (<i>EC Declaration Of Conformity</i>).	Pages 17 & 18

TOOL KIT

The following items are included with your locomotive.

One 60ml bottle of special steam oil for use in the cylinder lubricator.

One 60ml syringe with plastic tube for filling the boiler with water.

One water top up pump bottle.

One set of spare washers and 'O' rings.

One spare gas jet.

One Allen key for cylinder socket cap screws.

One wheel setting (back to back) gauge and key.

One pair of protective gloves.

One cleaning duster.

UN-PACKING THE MODEL

To prevent damage during transit, the model is packed in a polystyrene cradle, and certain items removed and packed separately in the top of the cradle. Carefully lift out the locomotive and fit the loose items as follows, using the photographs on the front cover and referring to the 'Un-Packing The Model' section.

1) The centre buffers fit through the horizontal slots in the front and rear buffer beams and are fixed by a shouldered pivot screw into the tapped hole on the underside of the casting.

2) The dummy re-railing pole has a groove on the rear end that fits into the slot on the front right hand side of the coal bunker. Lift out the dummy coal load and sit the pole in this slot and the support on the saddle tank, and then replace the coal load. The two dummy fire irons hang on the two hooks attached to the pole.

3) The dummy steam dome sits over the safety valve/filler plug on top of the boiler

4) The cab roof hinge fits into two holes in the top of the cab frame. Lightly spring the two ends of the hinge rod together between your fingers and insert the ends into the holes. The headlamp should be to the rear.

RUNNING IN

All locomotives are test run before leaving the factory, but will require several hours of running in, when new, to overcome initial tightness and allow valves etc. to 'bed in' completely. It is recommended that the model is run with light loads for the first few hours of operation. Also, the loco will waste a proportion of it's water and steam until 'run in' due to leaking slide valves, a tendency to prime more, and simply overcoming the initial tightness of the moving parts. As the model heats up and cools down each time you raise steam, screws and nuts have a tendency to stretch and loosen a little so you will also need to make regular checks and 'nip up' any that become loose. Most are quite visible and easy to get to however if there is any steam leaking from the valve chests on top of the cylinders, refer to the Trouble Shooting section.

ACCESS TO THE CONTROLS

For normal operation, all controls are accessible without the need to remove any part of the locomotive, however, for ease of servicing, the cab roof hinges up. Lift the roof vertically, then it will hinge over to the left hand side of the cab. The gas regulator and water top up valve are located in the right hand cab doorway. The gas filler valve is located on the top right hand side of the coal bunker. On manual control engines, the steam regulator is accessible through the right hand cab doorway, and reversing lever through the left hand cab doorway.

The displacement lubricator is positioned in the front left hand side of the cab.

The switch for the locomotive R/C equipment is on the underside of the left hand coal bunker.

The radio control batteries are housed in the bunker and are accessed by lifting out the dummy coal load.

The radio control receiver is in the dummy firebox ash pan beneath the cab floor.

IDENTIFICATION OF PARTS OF THE LOCOMOTIVE

Radio controlled version illustrated

- 1) Pressure gauge
- 2) Lubricator filler cap
- 3) Batteries (R/C version only)
- 4) Safety valve/filler plug
- 5) Gas burner
- 6) Steam regulator
- 7) Water top up valve
- 8) Gas regulator
- 9) Gas filler valve

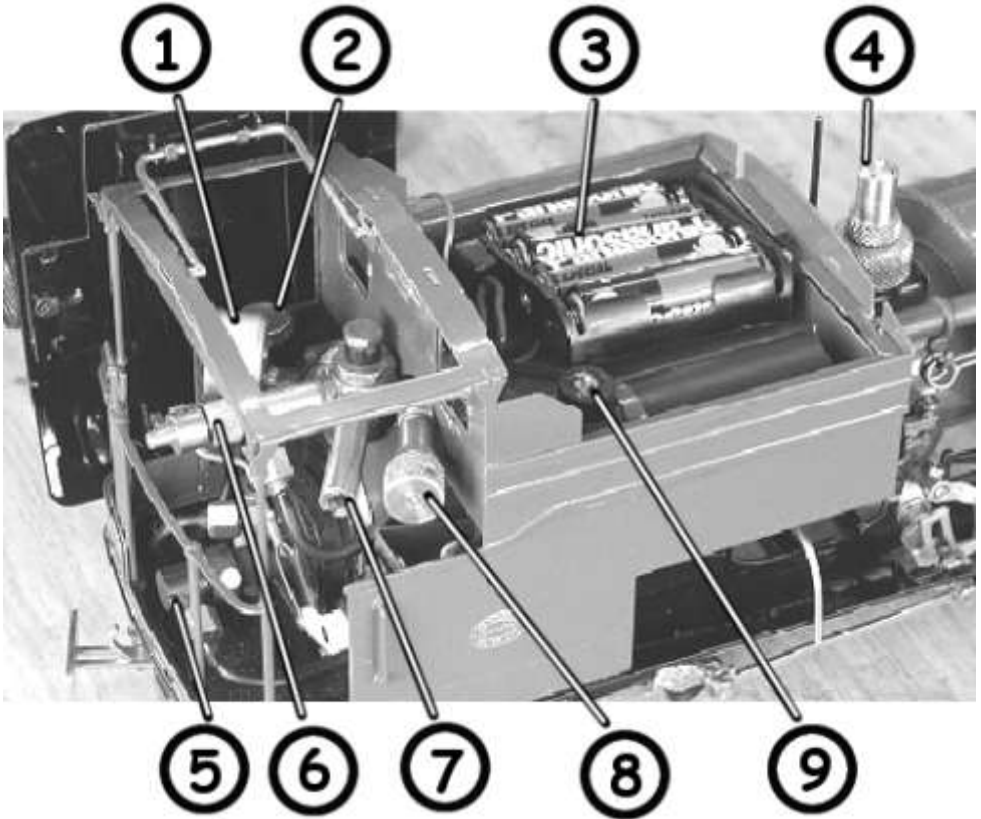

PREPARING FOR OPERATION

The locomotive must be serviced before being operated. It is important to perform all the following operations.

1) FILLING THE GAS TANK

The filling of the gas tank should only be carried out in a well-ventilated area, where there are no naked lights or other lighted locomotives close by. Ordinary Butane or Iso-butane gas (as used in gas cigarette lighters) is the preferred fuel, though for economy, the larger canisters as used for

blowlamps or camping stoves etc. are better. The larger canisters have an EN417 threaded self sealing valve on top and require a special adapter to couple up to the filler valve on the locomotive. A special brass gas filler adapter is obtainable from your local garden railway supplier or direct from **ROUNDHOUSE**.

Mixed gasses are also available and may be used if ordinary butane or iso-butane are not available, but see the 'Gas System' section for more information on this subject.

Before attempting to fill the gas tank, make sure that the gas control valve is closed by turning it clockwise.

The filler valve for the gas tank is on top of the coal bunker on the right hand side and is accessed through the hole in the dummy coal load. Invert the gas canister and place its nozzle over the gas filler valve. Support the tank from underneath and press the canister down. The gas will be heard hissing as it enters the tank and a small amount will escape around the valve. This is quite normal and is the tank venting as the liquid enters.

After about 20 to 30 seconds, liquid gas will emerge from the valve showing that the tank is full. Remove the canister immediately.

2) FILLING THE BOILER

A syringe and plastic pipe are supplied for filling of the boiler.

The boiler is filled with water through the safety valve bush, housed under the dummy steam dome on top of the boiler. The dome is a substantial and heavy item, being machined from solid brass. Care is needed when removing the dome, especially when the engine is hot, as the dome itself will be hot. Take care not to drop the dome onto the locomotive, as the weight of it may damage the model. Lift off the dome then remove the safety valve/filler plug by unscrewing it with the large knurled ring around its base. Fill the boiler right to the top with clean water. Distilled water is recommended if available. As an alternative to distilled water if this is unavailable, clean tap water can be used in soft water areas. Also, rain water or water from a dehumidifier can be used provided that it is adequately filtered. Many people now use rain water passed through a

paper wine or coffee filter to remove any particles or debris in the water.

Do not use deionised water as this type of water may cause long term damage to the boiler and fittings.

There has to be a space above the water to allow steam to be raised so, insert the end of the plastic pipe into the boiler and withdraw 30ml of water with the syringe. Replace the safety valve finger tight then place the dummy steam dome over it.

3) LUBRICATION

Regular lubrication of all working parts is important and should be carried out before each operating session. There are two types of lubrication required: The external moving linkages and bearings are lubricated with a medium oil such as motor engine oil, and the internal steam mechanisms such as cylinders, pistons and valves are lubricated with a special steam oil that is mixed with the steam. Infrequent external lubrication will allow parts to run dry, and over oiling can form pools around operating parts that attract dirt and grit. If too thin an oil is used it will evaporate very quickly as the loco gets hot – leading to dry running. We recommend the use of a 20-50 motor oil for external lubrication. When carrying out general lubrication, do not forget the regulator spindles (see Trouble Shooting section for further details of oiling the regulators).

Internal lubrication is achieved by steam oil that is mixed with the steam in the displacement lubricator, housed in the left-hand side of the cab. Remove the knurled cap from the top and slacken the drain screw two or three turns at the bottom but do not remove it. Any water in the lubricator will run out through the drain screw. Tighten the drain screw and refill with the steam oil supplied, then replace the cap. Take time filling the lubricator, especially when cold, as the oil takes time to run down and may trap an air bubble. Both cap and drain screw are fitted with ‘O’ rings and need only be closed finger tight.

NOTE: Only special steam oil as supplied should be used in the lubricator and under no circumstances should ordinary oil be substituted, or damage may result.

4) LIGHTING THE BURNER

WARNING: Before lighting read the section on gas system troubleshooting and be aware of potential problems. If the gas system is not operating correctly, **shut it off immediately** or damage may result.

Move the locomotive to another location before lighting. Butane is heavier than air and small pockets of gas can collect around the locomotive during filling.

To light the burner, hold a lighted match or cigarette lighter over the top of the chimney and **slowly** open the gas regulator by turning it anti-clockwise. The gas should ignite almost immediately with a pop as the flame travels down the chimney and into the boiler tube. The burner should be audible but not too loud.

NOTE as stated above, the gas regulator should be opened slowly until the burner ignites. If opened too quickly, particularly when the engine is cold or if the gas tank has just been filled, it is possible that the flame may not travel back into the boiler flue but stay in the smokebox. If this should happen, the burner will sound quite different to normal and the blue flame will be visible in the smokebox if viewed down the chimney from a safe height. Should this happen, turn off the gas immediately or damage may result and then re-light it. If the problem persists and it is not possible to ignite the burner correctly, then a dirty jet should be suspected and cleaned as detailed in the Gas System Troubleshooting Section.

For the first couple of minutes keep the burner on low. This is important, as until it warms up, the flame will be a little unstable and turning it up too much could cause it to go out. Also, with a completely full tank, liquid gas could be drawn off instead of vaporised gas, which can also extinguish the flame.

After a couple of minutes, the gas control valve can be opened more to speed up steam raising. Open the gas regulator slowly to about one full turn. The full range of adjustment (closed to fully open) is achieved within the **first full rotation** of the gas regulator knob any more is unnecessary.

RUNNING THE LOCOMOTIVE

When full working pressure has been reached (between 35 and 40psi), the safety valve will start to blow off steam. Steam generation can be controlled by the gas valve in the right hand cab doorway. If the safety valve blows off frequently during running, then too much steam is being produced which wastes water and gas. Turning down the burner will decrease the amount of steam created. Conversely, if steam pressure is not maintained during a run, then the burner should be turned up. After a few minutes of running it may be noticed that the gas pressure through the burner has increased. This is due to the gas tank becoming warmer and so increasing the gas pressure. Simply turn the gas down – this may need to be performed several times during a run. The art of balancing steam generation to the operational requirement by the adjustment of the gas control valve will quickly be learned.

The gas tank has a duration of about 25 minutes, though this will vary depending on gas valve setting. The boiler should not be allowed to run dry, and the gas tank capacity is such that the gas should run out before the water. When the gas is fully used up, the steam pressure in the boiler will be seen to gradually drop until the loco comes to a halt. Should the water expire before the gas is fully used, the pressure will drop rapidly and the loco will stop. Check the pressure gauge – if this is zero turn off the gas. No damage will result if the gas is turned off immediately. Never re-fill the gas tank without first re-filling the boiler.

DRIVING THE LOCOMOTIVE MANUALLY

On manually controlled locomotives, there are three main controls, all of which are housed in the cab.

- 1) The gas regulator, which should be used to control steam generation as described earlier.
- 2) The reversing lever. This is in the left-hand side of the cab and is moved fully forward for running in a forward direction and fully back to run in the reverse direction. It should be parked in the centre (mid gear) when the locomotive is stationary for any length of time. When in mid gear position, the valve gear is effectively in neutral and the engine will not move under steam power.

3) The steam regulator. This is the main steam control valve and regulates the speed at which the engine will run. The regulator handle is situated in the right hand cab doorway and is moved anti-clockwise to open and clockwise to close.

Using the reversing lever, select the desired direction of travel and open the regulator a little. Initially, there will be a certain amount of water in the pipes and cylinders, which will exhaust through the chimney and, after a few moments, the engine will move jerkily, until this clears. Once the parts have warmed up, the engine will move off steadily and it's speed can be controlled with the regulator. Subsequent starts will be quite smooth once the cylinders etc. have reached their normal operating temperature.

To reverse the locomotive, close the regulator to bring it to a halt, move the reversing lever over and open the regulator again.

The art of fine control will soon be learnt with a little practice.

DRIVING BY RADIO CONTROL

This model is fitted with 2.4 GHz R/C equipment. On a Radio Controlled model, speed and direction are controlled by the transmitter. . First, turn on the transmitter and then turn on the receiver in the locomotive using the switch under the left hand side of the coal bunker The left hand stick on the transmitter controls the steam regulator, down for stop up for go. Moving to the left or right has no function.

The right hand stick operates the reverser, left for forward and right for reverse. This stick is sprung loaded to return to it's central position. Moving up or down has no function

Using the transmitter, select the desired direction of travel and then slowly open the regulator. The locomotive will now move off as described in the manual control section..

For more information on using the radio control equipment, see the manufacturers instruction booklet supplied with the Radio Control Set.

The art of fine control will soon be learnt with a little practice

NOTE: Ensure that the valve gear is fully in gear for the required direction when the engine is moving. The model is fitted with a simplified Walschaerts type valve gear which is not suitable for 'notching up' (altering the cut off). Always bring the locomotive to a halt by closing the regulator before changing direction. If an emergency stop is required, simply release the reversing lever, which will spring back into mid gear and halt the train. Then close the regulator. Always ensure that the regulator is closed before switching off the transmitter.

Always switch off the receiver and transmitter when not in use to preserve battery life. It is good practice to switch on the transmitter before the receiver and switch off the receiver before the transmitter. In this way, the radio receiver is never on when the transmitter is switched off and so should always be under your control.

The radio control batteries are housed in the bunker and are accessed by lifting out the dummy coal load.

WATER TOP UP SYSTEM

A water top up system is fitted to this model. This enables the water level in the boiler to be monitored and topped up to keep the engine in steam for longer periods.

Once the locomotive is in operation as detailed in the previous sections, water can be added to the boiler at any time during the run as follows.

Fill the water pump bottle from your usual water supply.

Push the end of the plastic tube into the open end of the water filling valve on the right hand side of the turret and hold it in, but do not touch the hot boiler fittings.

Pump the handle and this will inject water into the boiler.

You will sometimes see water and air bubbles passing through the sight glass as you pump so allow the level to settle after a few pumps. Carefully

pull the plastic pipe out of the water filling valve whilst still steadying the engine.

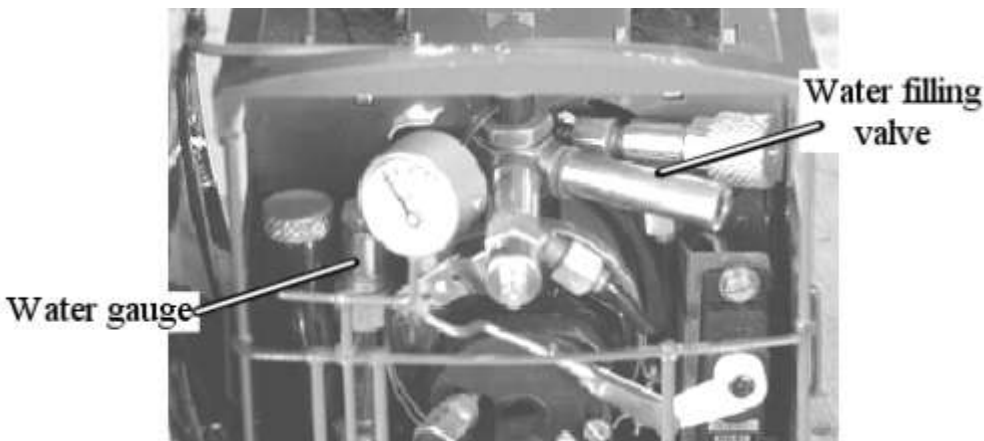

Occasionally small particles of dirt will find their way in with the water and may cause the water filling valve to leak back a little when the pipe is removed. If this should happen, re-connect the pipe and give a further pump or two of water to clear it.

Once you start running your loco you will see the water level in the gauge slowly dropping. Note that air bubbles may sometimes form in the gauge giving a false reading but these can be pushed out by connecting the pipe from the water pump to the water filling connector – and injecting some water.

It is better to pump small amounts of water into the boiler at frequent intervals. Aim to keep the water level between $\frac{1}{2}$ and $\frac{3}{4}$ up the gauge and re-fill the gas tank as detailed in the locomotive operating instructions whenever it is empty. In this way, you can keep the loco in steam and at working pressure as long as you like.

Don't forget to re-fill the displacement lubricator about every 30 minutes.

TROUBLESHOOTING & MAINTENANCE

On a working model of this nature, it is important to keep all working parts well lubricated.

With constant heating up, cooling down and the stresses of hard work, screws etc. can work loose so, it is good practice to check all fixings and cylinder screws regularly, but remember, never over tighten.

STORAGE BETWEEN OPERATING SESSIONS

At the end of an operating session, it is good practice to clean the locomotive carefully with a clean soft cloth, and to oil all bright metal parts.

- * Do not leave fuel or water in the tank or boiler for long periods.
- * Do not store in places where the temperature may drop below freezing as water may still be present in the pipework.
- * Ensure all controls are closed and the valve gear in mid gear.
- * Ensure that radio control equipment is switched off and, if the engine is not to be used for some time, remove all batteries.

Periodically it may be necessary to wash off all traces of dirt and old oil from the moving parts with paraffin (not thinners). This will remove any accumulations of dirt or grit. After washing with paraffin, leave to dry thoroughly overnight before re-oiling. It is most important that clean oil is applied and allowed to penetrate fully into all moving parts before the locomotive is run again. Manually moving the locomotive back and forth will assist in distributing the oil fully. Under normal operating conditions this procedure should not be required more than once or twice per year.

STEAM LEAKS

The cylinders are fitted with 'O' rings in the glands sealing the piston and valve rods. These can be adjusted with a spanner if steam leaks develop. They should only be tightened just enough to stop the leak, as over tightening will affect the running of the model.

REGULATOR NOT SHUTTING (R/C models)

The steam regulator seating and seal can, after a period of time become worn or compressed so that when the lever on the radio control is fully closed, the locomotive still moves. To overcome this, a trimmer is fitted to the transmitter. This is the small lever at the side of the main control lever

and is set at the factory to the top of its slot. As wear takes place in the regulator, it can slowly be moved down the slot to compensate. When it reaches the bottom, it is time to reset it to the top and adjust the linkage between the servo and the regulator in the cab. If adjustment does not cure this problem, the internal 'O' ring is probably damaged and requires replacement. Contact the factory for further advice. Periodic oiling of the gland will help keep the regulator working freely. Place a spot of motor oil between the gland nut and the regulator arm and work the regulator a few times.

RADIO CONTROL

If the radio control gives problems, always check the batteries first and replace if in doubt. AA size batteries are used, both in the locomotive and in the transmitter. For further details of the Radio Control equipment, refer to the manufacturers literature supplied.

GAS SYSTEM

Internally fired locomotives are fitted with our 'FG' type gas burner, which is set up and fully tested at the factory.

This system is designed for use with Butane or Iso-Butane gas. Mixed gasses, i.e. Butane with a proportion of Propane mixed in, are available, and may be used if straight Butane is unavailable. These come in a variety of mixes ranging from 90/10 to 60/40 with one of the most common being 70/30. The figures refer to the proportions of the mix i.e. 70/30 contains 70% butane and 30% propane. If using mixed gasses, always choose the one with the largest proportion of butane. The addition of propane slightly alters the gasses properties. This can make the burner a little more difficult to light when cold or after filling the gas tank.

Always open the regulator very slowly when lighting, and only just sufficient for ignition to take place. Opening too much too soon may extinguish the flame until the burner reaches normal operating temperature. The tiny jet in these units can become blocked by small particles of dirt making the burner difficult to light, burn weakly at normal operating temperatures*, burn in the smokebox or fail completely.

If any of these should happen, clean out the jet as follows. (* On very cold days, a burner may start off burning weakly due to the temperature of the

gas but should increase to its normal level as the engine warms up. This is quite normal). Carefully, disconnect the gas pipe from the jet block using a 2BA spanner.

Note when connecting or disconnecting the gas pipe and jet block, do not use excessive force. Always hold the end of the gas burner near the air holes to support it otherwise it is possible to cause damage by bending the body. Slacken the screw retaining the jet block and slide it out to the rear. Remove the jet from the jet block using a 4BA spanner. Wash out the jet in fast evaporating thinner (Cellulose or similar). Blow through the jet from the front, which should clear most blockages. Although the hole through the jet is tiny, if you hold it up to the light you should be able to see quite clearly if it is blocked or not. If in doubt, fit a new jet. A spare gas jet is included with the toolkit. Do not use wire to clean the jet as this can damage the precision hole and may upset the delicate balance of the gas system. Reassemble in the reverse order, putting a small amount of PTFE tape round the thread of the jet. Ensure all connections are tight. When re-positioning the jet block in the burner, ensure that it is pushed in as far as it will go.

The gas regulator has a spindle 'O' ring housed inside the body which may need lubrication from time to time if the control becomes 'spongy' in operation, making precise gas control difficult. As stated previously in the lighting instructions, the full range of adjustment for normal burner operation is achieved within the first full rotation of the regulator knob, and it should only be unscrewed more than this for maintenance purposes and when the tank is empty, and there are no naked lights nearby.

To lubricate it, remove the knurled knob which is retained by a 4BA socket grub screw (.100" AF Allen key required) in the side.

Beneath the knob is a back-lash spring and white PTFE washer which will slide off the spindle. Unscrew the hexagon retaining nut then screw the spindle out of the body. The 'O' ring can now be lubricated.

Replace the spindle followed by the retaining nut. Slide the white PTFE washer and backlash spring over the spindle and replace the knob. Note that the grub screw that holds the knob in place tightens into a groove near the end of the spindle.

ROUNDHOUSE



ROUNDHOUSE ENGINEERING CO. LTD.

Units 6-9 Churchill Business Park. Churchill Road.

Wheatley. Doncaster. DN1 2TF. England

Telephone 01302 328035 Fax 01302 761312

www.roundhouse-eng.com

Please refer to the ‘owners handbook’ for your particular model of locomotive, for details on correct use of these pressure vessels.

PRESSURE VESSEL CARE AND MAINTENANCE.

GAS TANK

The gas tank is used for the storage of LPG (liquefied petroleum gas) in the form of butane, iso-butane or as set out in the ‘owners handbook’.

The tank is fitted with a self-venting filler valve which contains no serviceable parts. Should the filler valve become defective in any way, it must be replaced with a new item.

It is recommended that the gas tank should undergo the following checks, carried out by a ‘competent person’, club, society or pressure vessel manufacturer, every year:-

1) thorough visual inspection.

And every five to ten years:-

1) hydrostatic pressure test to not less than 1.5 and not more than 2 times the maximum working pressure.

BOILER

The boiler is fitted with a safety valve to prevent the steam pressure rising above the maximum allowable working pressure. This is pre-set to open at between 2.38 bar (35 psi) and 2.72 bar (40 psi) and must not be adjusted to increase this value.

If the safety valve becomes defective in any way, it should be replaced or returned to the factory for service and calibration.

It is recommended that the boiler should undergo the following checks, carried out by a ‘competent person’, club, society, or pressure vessel manufacturer, every one to two years:-

1) thorough visual inspection.

2) hydrostatic pressure test to not less than 1.5 and not more than 2 times the maximum working pressure.

3) steam test to check the correct functioning of all steam controls, gauge and safety valve.



Gas Burner

1). Superheater Pipe.

2). Lubricator Pipe.

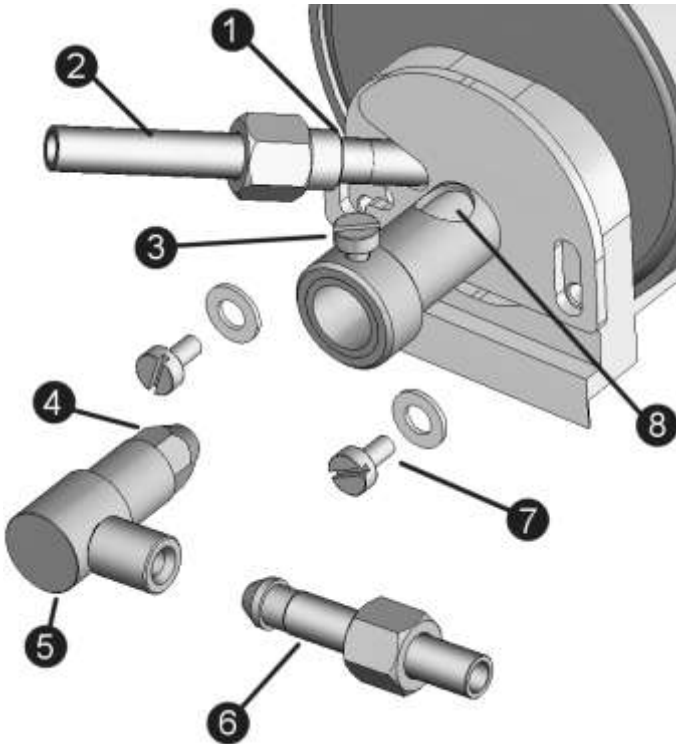

3). Gas Jet Block retaining screw.

4). Gas Jet.

5). Gas Jet Block.

6). Gas Pipe.

7). Gas Burner fixing screw.

8). Air Inlet Holes.

SERVICE AND PARTS

If any problems arise with this model which are not covered in these operating instructions or, spare parts are required, owners should first contact their local dealer. Your **ROUNDHOUSE** dealer is;



If your dealer is unable to help, you may contact the Factory directly:

ROUNDHOUSE ENGINEERING CO. LTD.

Units 6-9 Churchill Business Park. Churchill Road.

Wheatley. Doncaster. DN1 2TF. England

Telephone 01302 328035 Fax 01302 761312

e-mail support@roundhouse-eng.com

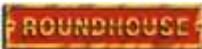

ONLINE

www.roundhouse-eng.com

