

**ROUNDHOUSE**

# JACK

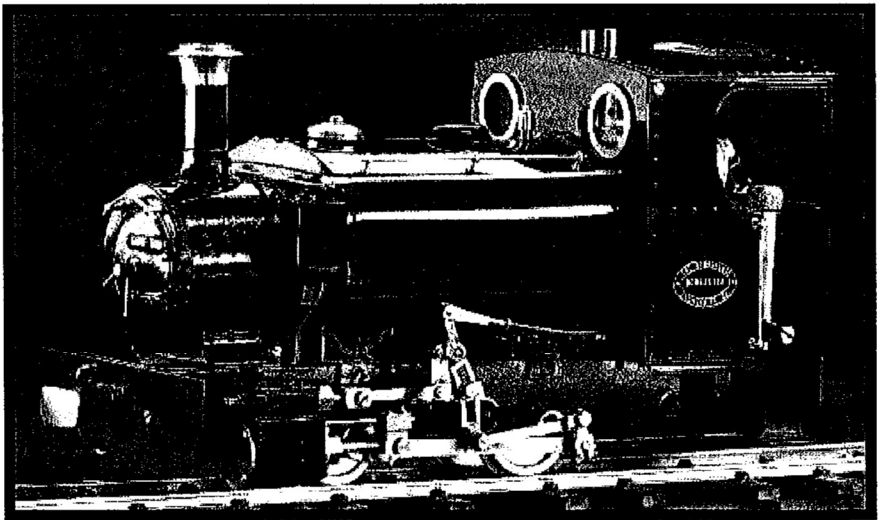

**Owners Handbook**  
For the Jack Locomotive

# Operating Instructions

**IMPORTANT:** Read these instructions carefully before operating the locomotive

The following items are required for running this engine and are not included with the model.

**Fuel**                      Butane gas. See 'Filling the gas tank'  
**Water**                      See 'Filling the boiler'  
**Lubricating oil**        See 'Lubrication'

## **SAFETY PRECAUTIONS**

This is a working model locomotive using steam under pressure and highly flammable fuel. Provided it is operated with reasonable care and attention, no problems should arise.

It is intended for use out of doors and must only be operated in a well-ventilated area.

Whilst the locomotive is in use, hot gasses are exhausted up the chimney and excess steam frequently blows off through the safety valve even when stationary, so operator and spectators should not bend over the model.

As you will appreciate, this is not a toy and is therefore unsuitable for young unsupervised children.

Follow manufacturers recommendations regarding the safe storage of Butane gas canisters.

Some areas of the model will get quite hot whilst it is operating, so a pair of gloves are provided in the tool kit for your protection.

Always have to hand either a fire extinguisher or wet cloth when operating the model.

# CONTENTS

Tool kit	Page 4
Running in	Page 4
Access to controls	Page 4
Identification of parts of the locomotive	Page 5
Preparations for operation	Page 6
1. Filling the Gas Tank	Page 6
2. Filling the Boiler	Page 6
3. Lubrication	Page 7
4. Lighting the Burner	Page 8
Running the locomotive	Page 9
Driving manually	Page 9
Driving by radio control	Page 10
Storage between operating sessions	Page 11
Altering wheel gauge	Page 11
Trouble shooting & maintenance	Page 12
Gas system	page 13
Service and parts	page 16

## **TOOL KIT**

The following items are included with your locomotive.

One 60ml bottle of special steam oil for use in the cylinder lubricator.

One 60ml syringe with plastic tube for filling the boiler with water.

One set of spare washers and 'O' rings.

One spare gas jet and gas filler valve.

One Allen key for cylinder socket cap screws.

One wheel setting (back to back) gauge and key.

One pair of protective gloves.

One cleaning duster.

## **RUNNING IN**

All locomotives are test run before leaving the factory, but will require several hours of running in, when new, to overcome initial tightness and allow valves etc. to 'bed in' completely. It is recommended that the model is run with light loads for the first few hours of operation. Also, the loco will waste a proportion of it's water and steam until 'run in' due to leaking slide valves, a tendency to prime more, and simply overcoming the initial tightness of the moving parts.

As the model heats up and cools down each time you raise steam, screws and nuts have a tendency to stretch and loosen a little so you will also need to make regular checks and 'nip up' any that become loose. Most are quite visible and easy to get to however if there is any steam leaking from the valve chests on top of the cylinders, refer to the Trouble Shooting section.

## **ACCESS TO THE CONTROLS**

For normal operation, all controls are accessible without the need to remove any part of the locomotive, however, to give access to the gas tank and safety valve when filling, the cab roof hinges up from the front. Care should be taken when opening the cab roof. Gently grasp either side of the roof hinge and firstly lift the hinge vertically upwards. This will lift the hinge clear of the cab, and allow the roof to then tilt forward.

The gas regulator is accessible through the rear of the cab and on manual control engines, the steam regulator is accessible through the right hand cab doorway and reversing lever through the left hand cab doorway.

The radio control receiver is housed in between the frames, below the cab floor. The switch is located on the right hand side of the chassis just below the cab footplate. The batteries for the radio control system are housed in the left hand side of the saddle tank and are accessed by removing the body as follows. Lift up the cab roof and disconnect the aerial wire at the connector with the dummy roof vent.

Remove the screw in the centre of the dome on top of the saddle tank.  
Lift the body vertically a little to access the snap on connector for the batteries in the left hand of the saddle tank and disconnect.  
The body can now be lifted off, springing the cab out a little to clear the steam fittings. Once off, the batteries can be slid out of the body through the rear. Re-fit in reverse order.

## IDENTIFICATION OF PARTS OF THE LOCOMOTIVE

Radio controlled version illustrated

1/ Lubricator drain screw. 2/ Lubricator filler cap.

3/ Reversing servo. **Note:** this is replaced by a reversing lever on manual models.

4/ Pressure gauge. 5/ Safety valve 6/ Gas regulator. 7/ Gas filler valve.

8/ Steam regulator. 9/ Steam regulator servo and linkage. 10/ Gas burner.

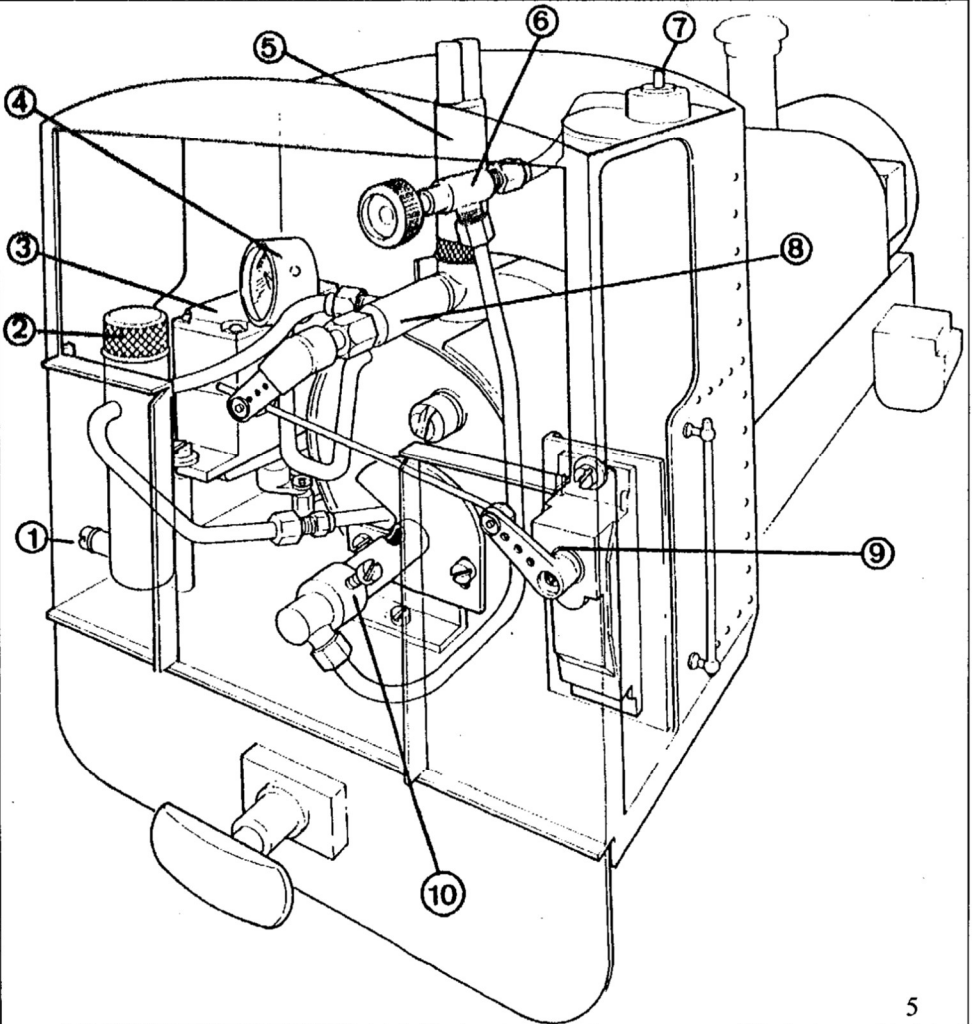

## **PREPARING FOR OPERATION**

The locomotive must be serviced before being operated. It is important to perform all the following operations.

### **1) FILLING THE GAS TANK**

The filling of the gas tank should only be carried out in a well-ventilated area, where there are no naked lights or other lighted locomotives close by. Ordinary Butane gas is used (as used in gas cigarette lighters), though for economy, the larger canisters as used for blowlamps or camping stoves etc. are better. The larger canisters require a special adapter to couple up to the filler valve on the locomotive and some brands are supplied with a small plastic adapter which does this job. If however one is not available, a special brass adapter is obtainable from your local garden railway supplier or direct from **ROUNDHOUSE**.

Mixed gasses (70-30 Butane/Propane) are also available, but these should under no circumstances be used.

### **USE BUTANE ONLY.**

Before attempting to fill the gas tank, make sure that the gas control valve is closed by turning it clockwise.

The filler valve for the gas tank is on top of the tank under the cab roof. Invert the gas canister and place its nozzle over the gas filler valve. Support the tank from underneath and press the canister down. The gas will be heard hissing as it enters the tank and a small amount will escape around the valve. This is quite normal and is the tank venting as the liquid enters. After about 20 to 30 seconds, liquid gas will emerge from the valve showing that the tank is full. Remove the canister immediately.

### **2) FILLING THE BOILER**

A syringe and plastic pipe are supplied for filling of the boiler.

The boiler is filled with water, by removing the safety valve which is located in the cab. Fill the boiler right to the top with clean water.

Distilled water is recommended if available.

As an alternative to distilled water if this is unavailable, clean tap water can be used in soft water areas. Also, rain water or water from a dehumidifier can be used provided that it is adequately filtered.

Do not use deionised water as this type of water may cause long term damage to the boiler and fittings.

There has to be a space above the water to allow steam to be raised so, insert the end of the plastic pipe into the boiler and withdraw 30ml of water with the syringe. Replace the safety valve finger tight.

### **3) LUBRICATION**

Regular lubrication of all working parts is important and should be carried out before each operating session. There are two types of lubrication required: The external moving linkages and bearings are lubricated with a medium oil such as motor engine oil, and the internal steam mechanisms such as cylinders, pistons and valves are lubricated with a special steam oil that is mixed with the steam. Infrequent external lubrication will allow parts to run dry, and over oiling can form pools around operating parts that attract dirt and grit. If too thin an oil is used it will evaporate very quickly as the loco gets hot – leading to dry running. We recommend the use of a 20-50 motor oil for external lubrication.

Internal lubrication is achieved by steam oil that is mixed with the steam in the displacement lubricator, housed in the left-hand side of the cab. Remove the knurled cap from the top and slacken the drain screw two or three turns at the bottom but do not remove it. Any water in the lubricator will run out through the drain screw. Tighten the drain screw and refill with the steam oil supplied, then replace the cap. Take time filling the lubricator, especially when cold, as the oil takes time to run down and may trap an air bubble. Both cap and drain screw are fitted with 'O' rings and need only be closed finger tight.

**NOTE:** Only special steam oil as supplied should be used in the lubricator and under no circumstances should ordinary oil be substituted, or damage may result.

The gas and steam regulators will require periodic lubrication – see the troubleshooting section for details.

### 3) LIGHTING THE BURNER

**WARNING:** Before lighting read the section on gas system troubleshooting (page 13) and be aware of potential problems. If the gas system is not operating correctly, **shut it off immediately** or damage may result.

Move the locomotive to another location before lighting. Butane is heavier than air and small pockets of gas can collect around the locomotive during filling.

To light the burner, hold a lighted match or cigarette lighter over the top of the chimney and **slowly** open the gas regulator by turning it anti-clockwise. The gas should ignite almost immediately with a pop as the flame travels down the chimney and into the boiler tube. The burner should be audible but not too loud.

**NOTE** as stated above, the gas regulator should be opened slowly until the burner ignites. If opened too quickly, particularly when the engine is cold or if the gas tank has just been filled, it is possible that the flame may not travel back into the boiler flue but stay in the smokebox. If this should happen, the burner will sound quite different to normal and the blue flame will be visible in the smokebox if viewed down the chimney from a safe height. Should this happen, turn off the gas immediately or damage may result and then re-light it. If the problem persists and it is not possible to ignite the burner correctly, then a dirty jet should be suspected and cleaned as detailed on page 13.

For the first couple of minutes keep the burner on low. This is important, as until it warms up, the flame will be a little unstable and turning it up too much could cause it to go out. Also, with a completely full tank, liquid gas could be drawn off instead of vaporized gas, which can also extinguish the flame.

After a couple of minutes, the gas control valve can be opened more to speed up steam raising. Open the gas regulator slowly to about one full turn. The full range of adjustment (closed to fully open) is achieved within the **first full rotation** of the gas regulator knob any more is unnecessary.

### RUNNING THE LOCOMOTIVE

When full working pressure has been reached (about 40psi), the safety valve will start to blow off steam. Steam generation can be controlled by the gas valve in the cab. If the safety valve blows off frequently during running, then too much steam is being produced, which wastes water and gas. Turning down the burner will decrease the amount of steam created. Conversely, if steam pressure is not maintained during a run, then the burner should be



turned up. After a few minutes of running it may be noticed that the gas pressure through the burner has increased. This is due to the gas tank becoming warmer and so increasing the gas pressure. Simply turn the gas down – this may need to be performed several times during a run. The art of balancing steam generation to the operational requirement by the adjustment of the gas control valve will quickly be learned.

The gas tank has a duration of about 25 minutes, though this will vary a little depending on gas valve setting. The boiler should not be allowed to run dry, and the gas tank capacity is such that the gas should run out before the water. When the gas is fully used up, the steam pressure in the boiler will be seen to gradually drop until the loco comes to a halt. Should the water expire before the gas is fully used, the pressure will drop rapidly and the loco will stop. Check the pressure gauge – if this is zero turn off the gas. No damage will result if the gas is turned off immediately.

## **DRIVING THE LOCOMOTIVE MANUALLY**

On manually controlled locomotives, there are three main controls, all of which are housed in the cab.

- 1) The gas regulator, which should be used to control steam generation as described earlier.
- 2) The reversing lever. This is in the left-hand side of the cab and is moved fully forward for running in a forward direction and full back to run in the reverse direction. It should be parked in the centre (mid gear) when the locomotive is stationary for any length of time. When in mid gear position, the valve gear is effectively in neutral and the engine will not move under steam power.
- 3) The regulator. This is the main steam control valve and regulates the speed at which the engine will run. The regulator handle is situated in the right hand cab doorway and is moved anti-clockwise to open and clockwise to close. Using the reversing lever, select the desired direction of travel and open the regulator a little. Initially, there will be a certain amount of water in the pipes and cylinders, which will exhaust through the chimney and, after a few moments, the engine will move jerkily, until this clears. Once the parts have warmed up, the engine will move off steadily and it's speed can be controlled with the regulator. Subsequent starts will be quite smooth once the cylinders etc. have reached their normal operating temperature.  
To reverse the locomotive, close the regulator to bring it to a halt, move the reversing lever over and open the regulator again.

The art of fine control will soon be learnt with a little practice.

## **DRIVING BY RADIO CONTROL**

On a radio controlled model, speed and direction are controlled by moving the two levers on the transmitter supplied. The left hand lever operates the steam regulator, down for stop, up for go and the right hand lever operates the reversing valve gear, left for forward, right for reverse and centre for mid gear (neutral).

Switch on the transmitter with the switch in the centre of the front panel. The battery meter above should indicate that the batteries are OK. Switch on the receiver on the locomotive with the switch on the right hand side of the chassis just below the cab footplate. Select the desired direction of travel by holding the right hand lever fully over, and then open the regulator a little by moving the left-hand lever upwards slowly. The locomotive will now move off as described in the manual control section.

The art of fine control will soon be learnt with a little practice.

### **NOTE:**

Always hold the reversing lever fully over in the required direction when the engine is moving. The model is fitted with a simplified Walschaerts type valve gear which is not suitable for 'notching up' (altering the cut off).

Always bring the locomotive to a halt by closing the regulator before changing direction.

If an emergency stop is required, simply release the reversing lever, which will spring back into mid gear and halt the train. Then close the regulator.

Always ensure that the regulator is closed before switching off the transmitter.

Always switch off the receiver and transmitter when not in use to preserve battery life.

It is good practice to switch on the transmitter before the receiver and switch off the receiver before the transmitter. In this way, the radio receiver is never on when the transmitter is switched off and so should always be under your control.

When the batteries are getting low, a poor signal between transmitter and receiver will result and control of the engine will become erratic. The transmitter batteries are housed in the back of the unit under a clip off panel.

The receiver batteries are housed in a holder beneath the cab roof.

## **STORAGE BETWEEN OPERATING SESSIONS**

At the end of an operating session, it is good practice to clean the locomotive carefully with a clean soft cloth, and to oil all bright metal parts.

- \* Do not leave fuel or water in the tank or boiler for long periods.
- \* Do not store in places where the temperature may drop below freezing as water may still be present in the pipework.
- \* Ensure all controls are closed and the valve gear in mid gear.
- \* Ensure that radio control equipment is switched off and, if the engine is not to be used for some time, remove all batteries.

Periodically, wash off all traces of dirt and old oil from the moving parts with paraffin (not thinners) and apply fresh oil. This will stop the build up of dirt and grit.

## **ALTERING WHEEL GAUGE**

The wheels are set at the factory for the specified gauge however, for those who wish to alter this to run on other peoples railways or if you change the gauge of your track, they are easily reset with the aid of the back to back gauge supplied in the toolkit.

The driving wheels are moveable on their axles and are locked in place by a small grub screw. They should be adjusted so that the "back to back" gauge supplied in the kit will just slip between their inner faces.

Ensure that the wheels are evenly spaced relative to each side frame.  
Do not over tighten the grub screws particularly on insulated wheels.

## **TROUBLE SHOOTING & MAINTENANCE**

On a working model of this nature, it is important to keep all working parts well lubricated.

### **STEAM LEAKS**

The cylinders are fitted with 'O' rings in the glands sealing both piston and valve rods. These can be adjusted with a spanner if steam leaks develop. They should only be tightened just enough to stop the leak, as over tightening will affect the running of the model. Cylinder covers are fitted with gaskets and valve chests with 'O' rings . A little 'bubbling' of oil may sometimes occur around these and is quite normal, however, steam leaking past the gasket should be attended to. If 'nipping up' retaining screws does not stop a steam leak, a service kit is available which includes replacement gaskets and seals and full instructions for fitting. Valve chest screws on top of the cylinders are accessed by removal of the dummy cylinder cover which simply clips round the cylinder. Spring it gently out from the bottom and lift off the valve chest at the top.

### **REGULATOR NOT SHUTTING (R/C models)**

The steam regulator seating and seal can, after a period of time become worn or compressed so that when the lever on the radio control is fully closed, the locomotive still moves. To overcome this, a trimmer is fitted to the transmitter. This is the small lever at the side of the main control lever and is set at the factory to the top of its slot. As wear takes place in the regulator, it can slowly be moved down the slot to compensate. When it reaches the bottom, it is time to reset it to the top and adjust the linkage between the servo and the regulator in the cab. If adjustment does not cure this problem, the internal 'O' ring may be damaged and requires replacement. Contact the factory for further advice. Periodic oiling of the gland will help keep the regulator working freely. Place a spot of motor oil between the gland nut and the regulator arm and work the regulator a few times.

### **RADIO CONTROL**

If the radio control gives problems, always check the batteries first and replace if in doubt. AA size batteries are used, four in the locomotive and eight in the transmitter. If problems occur whilst running the locomotive near other r/c engines, check that yours is on a different frequency.

To allow a number of locomotives to operate at the same time in close proximity, a range of crystals are available for different frequencies, which can be purchased from any good model shop. Crystals operate in pairs, one in the transmitter and one in the receiver. They are clearly marked with the

frequency and either TX or RX. When fitting, ensure that the one marked TX is fitted to the transmitter and RX to the receiver. Two radio systems are currently in use, 40MHz FM and 27MHz AM. **ROUNDHOUSE** now only use 27MHz AM sets for USA and CANADA. Ensure that the replacement crystals are of the correct type.

It is common practice with radio controlled sets to attach a white marker or label to the aerial with the frequency or band number clearly marked in black. For further details of the r/c equipment, refer to the manufacturers literature supplied.

## **GAS SYSTEM**

Jack locomotives are fitted with our 'FG' type gas burner, which is set up and fully tested at the factory.

This system is designed for use with Butane gas as stated earlier, though Iso-Butane may also be used. Mixed gasses, i.e. Butane with a proportion of Propane mixed in, are available, but should not be used in this model as the pressure of the gas in the tank is much higher and it's burning properties somewhat different. Propane also requires a different fuel/air mixture to Butane, even when the two are mixed and this can cause the flame to become unstable and the burner to malfunction.

The tiny jet in these units can become blocked by small particles of dirt making the burner difficult to light, burn weakly at normal operating temperatures\*, burn in the smokebox or fail completely. If any of these should happen, clean out the jet as follows.

(\* On very cold days, a burner may start off burning weakly due to the temperature of the gas but should increase to its normal level as the engine warms up. This is quite normal)

Carefully, disconnect the gas pipe from the jet block using a 2BA spanner.

**Note** when connecting or disconnecting the gas pipe and jet block, do not use excessive force. Always hold the end of the gas burner near the air holes to support it otherwise it is possible to cause damage by bending the body. Slacken the screw retaining the jet block and slide it out to the rear. Remove the jet from the jet block using a 4BA spanner. Wash out the jet in fast evaporating thinner (Cellulose or similar). Blow through the jet from the front, which should clear most blockages. Although the hole through the jet is tiny, if you hold it up to the light you should be able to see quite clearly if it is blocked or not. If in doubt, fit a new jet. A spare gas jet is included with the toolkit. Do not use wire to clean the jet as this can damage the precision hole and may upset the delicate balance of the gas system. Reassemble in the reverse order, putting a small amount of PTFE tape round the thread of the jet.

Ensure all connections are tight. When re-positioning the jet block in the burner, ensure that it is pushed in as far as it will go.

The gas regulator has a spindle 'O' ring housed inside the body which may need lubrication from time to time if the control becomes 'spongy' in operation, making precise gas control difficult.

As stated in the lighting instructions on page 8, the full range of adjustment for normal burner operation is achieved within the first full rotation of the regulator knob, and it should only be unscrewed more than this for maintenance purposes and when the tank is empty, and there are no naked lights nearby.

To lubricate it, remove the knurled knob which is retained by a 4BA socket grub screw (.100" AF Allen key required) in the side.

Beneath the knob is a back-lash spring which will slide off the spindle.

Unscrew the hexagon retaining nut then screw the spindle out of the body.

The 'O' ring can now be lubricated.

Replace the spindle followed by the retaining nut. Slide the backlash spring over the spindle and replace the knob. Note that the grub screw that holds the knob in place tightens into a groove near the end of the spindle and should be in a position that allows the side handle to be screwed in and operate the regulator without fouling other controls or the cab side.

---

## Gas Burner

- 1/ Gas jet. 2/ Gas jet block.  
3/ Gas jet block retaining screw.  
4/ Gas pipe. 5/ Air holes

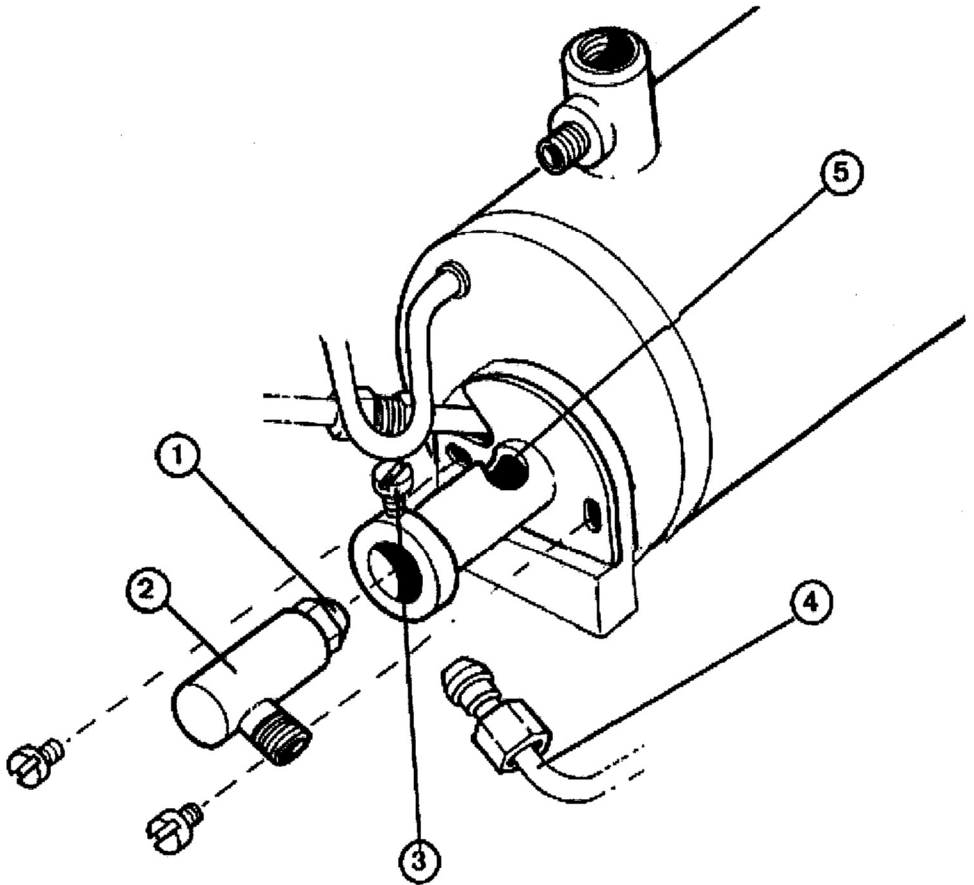

## SERVICE AND PARTS

If any problems arise with this model which are not covered in these operating instructions or, spare parts are required, owners should first contact their local dealer.

Your **ROUNDHOUSE** dealer is;

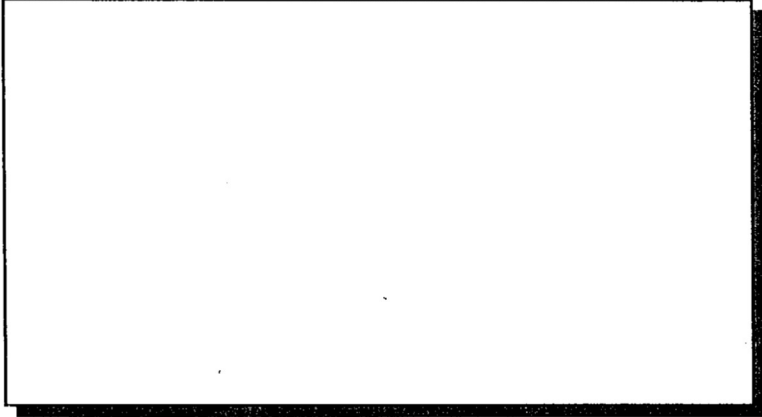

If your dealer is unable to help you may contact the Factory directly:

### **ROUNDHOUSE ENGINEERING CO. LTD.**

Units 6-7 Churchill Business Park.

Churchill Road. Wheatley.

Doncaster. DN1 2TF. England

Telephone 01302 328035

Fax 01302 761312

e-mail [support@roundhouse-eng.com](mailto:support@roundhouse-eng.com)



[www.roundhouse-eng.com](http://www.roundhouse-eng.com)  
or  
[www.roundhouse-eng.co.uk](http://www.roundhouse-eng.co.uk)